

Extraflame®

Riscaldamento a Pellet



UK

THERMO PRODUCTS USER MANUAL

ISIDORA IDRO H16 - H20

MADE IN ITALY
design & production

004280106 - REV 001

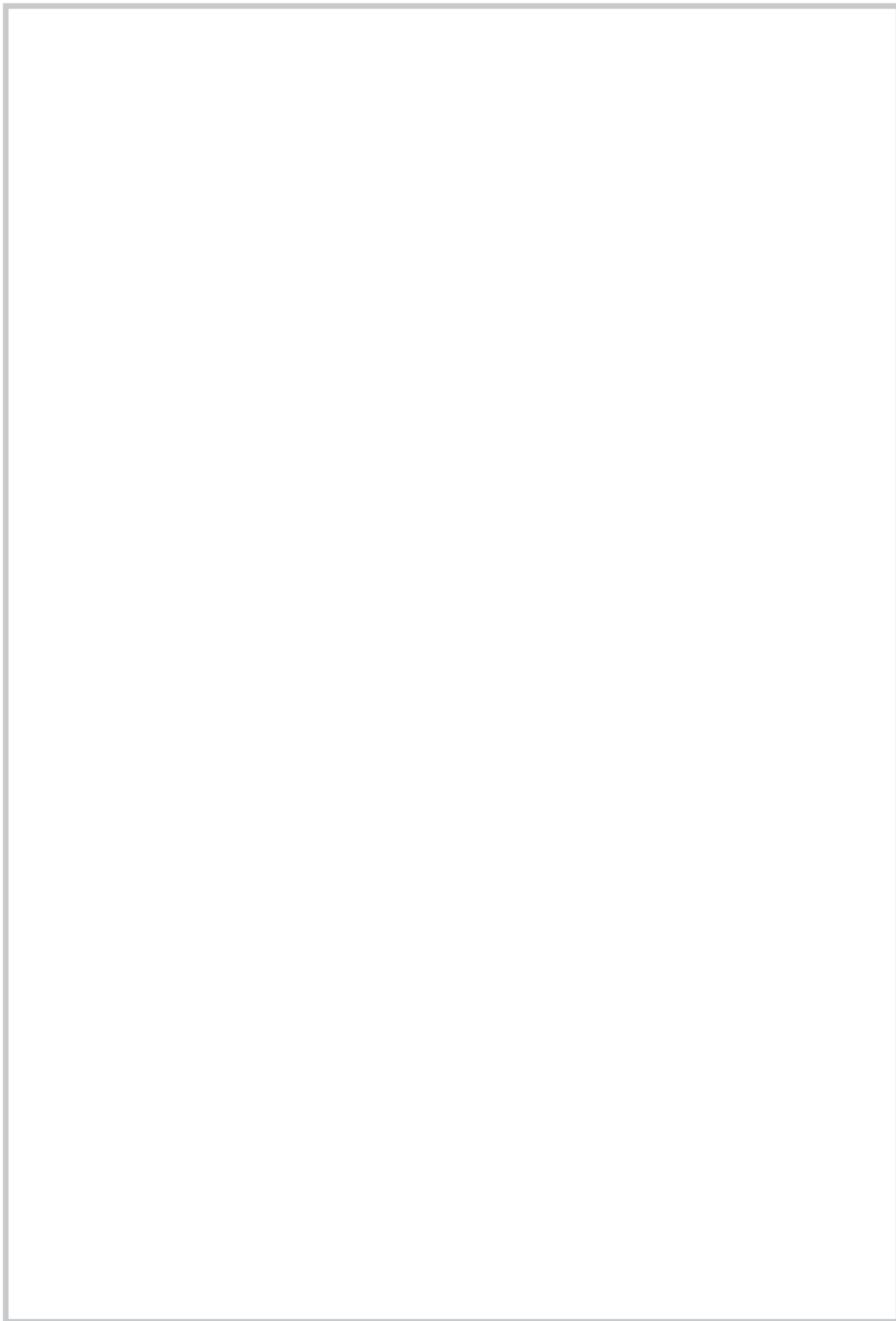

ATTENTION



**SURFACES CAN BECOME VERY HOT!
ALWAYS USE PROTECTIVE GLOVES!**

During combustion, thermal energy is released that significantly increases the heat of surfaces, doors, handles, controls, glass, exhaust pipes, and even the front of the appliance. Avoid contact with those elements if not wearing protective clothing (protective gloves included). Make sure children are aware of the danger and keep them away from the stove during operation.

ENGLISH	6
WARNINGS	6
SAFETY	6
ROUTINE MAINTENANCE	8
INSTALLATION	9
PREPARATIONS FOR MAINTENANCE	9
HYDRAULIC SYSTEM	11
INSTALLATION AND SAFETY DEVICES	11
ANTI-CONDENSATION DEVICE (MANDATORY)	12
DETAILS ISIDORA H16 - H20	13
FEATURES	14
CHECKS AND MEASURES FOR COMMISSIONING	14
THE PELLET LOAD MOTOR DOES NOT FUNCTION:	14
BULB THERMOSTATS - RESET	14
STOVE POSITIONING	15
NOTE FOR CORRECT OPERATION	15
RESETTING	15
FUSE	15
PELLETS AND FEEDING	16
PELLET HOPPER - PRESSURISED CLOSURE	16
REMOTE CONTROL	17
REMOTE CONTROL ICONS	18
INSERTING THE BATTERIES	18
ADVICE AND PRECAUTIONS FOR THE USE OF THE REMOTE CONTROL	18
TOUCH SCREEN DISPLAY	19
OPENING THE DISPLAY	19
CLOSING THE DISPLAY	19
CONTROL BOARD	20
ICON KEY	20
GENERAL MENU	21
GENERAL WARNINGS	21
FIRST IGNITION SETTINGS	22
DATE-TIME	22
LANGUAGE	22
DEGREES	22
OPERATION AND LOGIC	23
STAND-BY - ADDITIONAL THERMOSTAT	24
ADDITIONAL THERMOSTAT FUNCTIONING WITH STAND-BY ACTIVE	24
ADDITIONAL THERMOSTAT OPERATION WITH STAND-BY DEACTIVATED	24
ADDITIONAL THERMOSTAT INSTALLATION	24
VENTILATION	25
EASY SETUP	25
CHRONO	26
ENABLING/DISABLING THE CHRONO	26
SETTINGS	28
DISPLAY	28
STAND - BY	28
FIRST LOAD	28
OUTLET AIR	28
CLEANING	29
Wi-Fi	29
RESET	29
AUX	29
OPTIONAL ADDITIONAL DATA SHEET	29
CLEANING AND MAINTENANCE	30
MAINTENANCE	30
PERIODIC CLEANING UNDER USER'S RESPONSIBILITY	30
ROUTINE MAINTENANCE PERFORMED BY QUALIFIED TECHNICIANS	33
SHUT-DOWN (END OF SEASON)	33
DISPLAYS	35
ALARMS	35
GUARANTEE TERMS	37
DISPOSAL	38

**IT - ATTENZIONE TASSATIVO
PRIMA DI MOVIMENTARE LA STUFA
TOGLIERE IL RIVESTIMENTO INDICATO
PER EVITARE DANNI.**

**EN - WARNING
BEFORE HANDLING THE STOVE, THE
COVERING INDICATED MUST BE REMOVED
TO AVOID DAMAGE.**

**FR - ATTENTION IMPÉRATIF
AVANT DE DÉPLACER LE POÊLE, RETIRER
LE REVÊTEMENT INDIQUÉ
POUR ÉVITER TOUT DOMMAGE.**

**DE - ACHTUNG PFLICHT
BEVOR DER OFEN BEWEGT WIRD, MUSS DIE
ANGEZEIGTE VERKLEIDUNG ENTFERNT WER-
DEN, UM SCHÄDEN ZU VERMEIDEN.**

**ES - ATENCIÓN TAXATIVO
ANTES DE MANEJAR LA ESTUFA QUITA EL
REVESTIMIENTO INDICADO
PARA EVITAR DAÑOS.**

**PT - ATENÇÃO OBRIGATÓRIO
ANTES DE MOVIMENTAR O AQUECEDOR,
RETIRAR O REVESTIMENTO INDICADO
PARA EVITAR DANOS.**

**DK - OBS
FJERN DET ANGIVNE DÆKSEL, INDEN
OVNEN FLYTTES
FOR AT UNDGÅ SKADE.**

ISIDORA H16

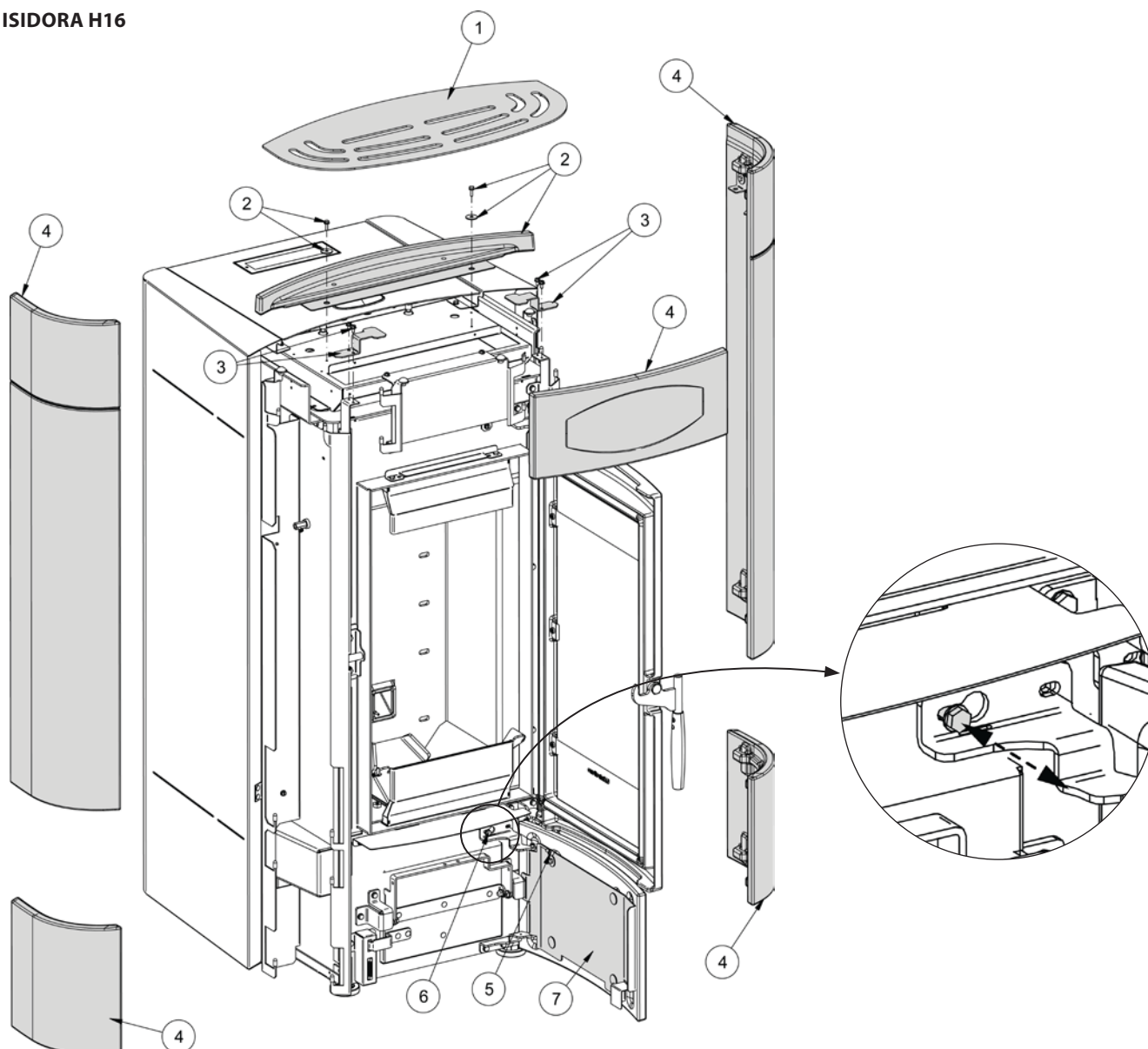

**IT - ATTENZIONE TASSATIVO
PRIMA DI MOVIMENTARE LA STUFA
TOGLIERE IL RIVESTIMENTO INDICATO
PER EVITARE DANNI.**

**EN - WARNING
BEFORE HANDLING THE STOVE, THE
COVERING INDICATED MUST BE REMOVED
TO AVOID DAMAGE.**

**FR - ATTENTION IMPÉRATIF
AVANT DE DÉPLACER LE POÊLE, RETIRER
LE REVÊTEMENT INDIQUÉ
POUR ÉVITER TOUT DOMMAGE.**

**DE - ACHTUNG PFLICHT
BEVOR DER OFEN BEWEGT WIRD, MUSS DIE
ANGEZEIGTE VERKLEIDUNG ENTFERNT WER-
DEN, UM SCHÄDEN ZU VERMEIDEN.**

**ES - ATENCIÓN TAXATIVO
ANTES DE MANEJAR LA ESTUFA QUITE EL
REVESTIMIENTO INDICADO
PARA EVITAR DAÑOS.**

**PT - ATENÇÃO OBRIGATÓRIO
ANTES DE MOVIMENTAR O AQUECEDOR,
RETIRAR O REVESTIMENTO INDICADO
PARA EVITAR DANOS.**

**DK - OBS
FJERN DET ANGIVNE DÆKSEL, INDEN
OVNEN FLYTTES
FOR AT UNDGÅ SKADE.**

ISIDORA H20

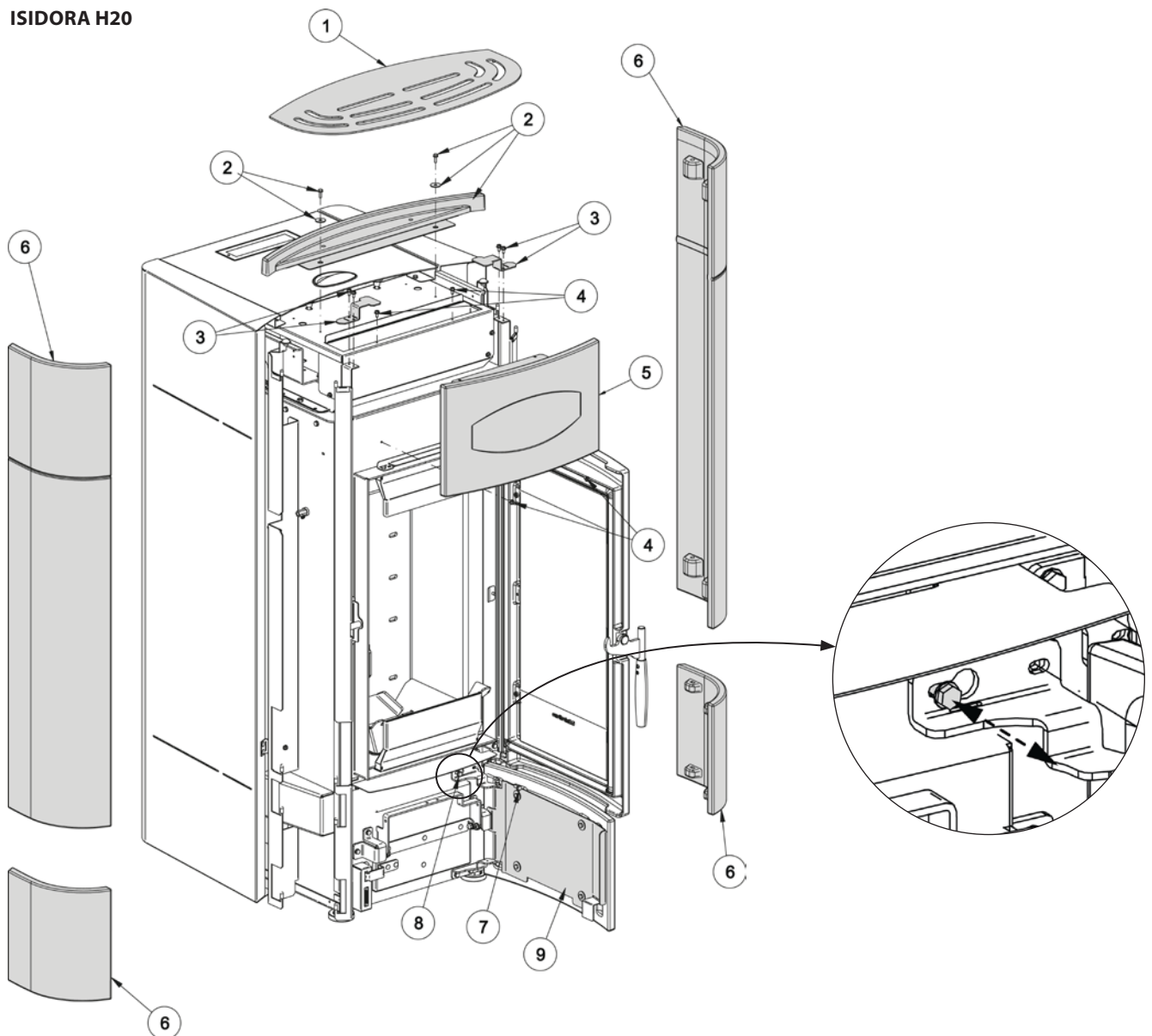

We thank you for having chosen our company; our product is a great heating solution developed from the most advanced technology with top quality machining and modern design, aimed at making you enjoy the fantastic sensation that the heat of a flame gives, in complete safety.

WARNINGS

This instructions manual is an integral part of the product: make sure that it always accompanies the appliance, even if transferred to another owner or user, or if transferred to another place. If it is damaged or lost, request another copy from the area technician. This product is intended for the use for which it has been expressly designed. The manufacturer is exempt from any liability, contractual and extracontractual, for injury/damage caused to persons/animals and objects, due to installation, adjustment and maintenance errors and improper use.

Installation must be performed by qualified staff, which assumes complete responsibility for the definitive installation and consequent good functioning of the product installed. One must also bear in mind all laws and national, regional, provincial and town council Standards present in the country in which the appliance has been installed, as well as the instructions contained in this manual.

The Manufacturer cannot be held responsible for the failure to comply with such precautions.

After removing the packaging, ensure that the content is intact and complete. Otherwise, contact the dealer where the appliance was purchased. All electric components that make up the product must be replaced with original spare parts exclusively by an authorised after-sales centre, thus guaranteeing correct functioning.

SAFETY

- ◆ **THE APPLIANCE MAY BE USED BY CHILDREN 8 YEARS OF AGE OR OLDER AND INDIVIDUALS WITH REDUCED PHYSICAL, SENSORY, OR MENTAL CAPACITIES OR WITHOUT EXPERIENCE OR THE NECESSARY KNOWLEDGE, PROVIDED THAT THEY ARE SUPERVISED OR HAVE RECEIVED INSTRUCTIONS ON SAFE USE OF THE APPLIANCE AND THAT THEY UNDERSTAND THE INHERENT DANGERS.**
- ◆ **THE GENERATOR MUST NOT BE USED BY PERSONS (INCLUDING**

CHILDREN) WITH REDUCED PHYSICAL, SENSORY AND MENTAL CAPACITIES OR WHO ARE UNSKILLED PERSONS, UNLESS THEY ARE SUPERVISED AND TRAINED REGARDING USE OF THE APPLIANCE BY A PERSON RESPONSIBLE FOR THEIR SAFETY.

- ◆ THE CLEANING AND MAINTENANCE REQUIRED BY THE USER MUST NOT BE PERFORMED BY CHILDREN WITHOUT SUPERVISION.
- ◆ CHILDREN MUST BE CHECKED TO ENSURE THAT THEY DO NOT PLAY WITH THE APPLIANCE.
- ◆ DO NOT TOUCH THE GENERATOR WHEN YOU ARE BAREFOOT OR WHEN PARTS OF THE BODY ARE WET OR DAMP.
- ◆ THE SAFETY AND ADJUSTMENT DEVICES MUST NOT BE MODIFIED WITHOUT THE AUTHORISATION OR INDICATIONS OF THE MANUFACTURER.
- ◆ DO NOT PULL, REMOVE, TWIST THE ELECTRICAL CABLES COMING OUT OF THE PRODUCT EVEN IF IT IS DISCONNECTED FROM THE MAINS.
- ◆ IT IS ADVISED TO POSITION THE POWER SUPPLY CABLE SO THAT IT DOES NOT COME INTO CONTACT WITH HOT PARTS OF THE APPLIANCE.
- ◆ THE POWER SUPPLY PLUG MUST BE ACCESSIBLE AFTER INSTALLATION.
- ◆ DO NOT CLOSE OR REDUCE THE DIMENSIONS OF THE AIRING VENTS IN THE PLACE OF INSTALLATION. THE AIRING VENTS ARE ESSENTIAL FOR CORRECT COMBUSTION.
- ◆ DO NOT LEAVE THE PACKAGING ELEMENTS WITHIN REACH OF CHILDREN OR UNASSISTED DISABLED PERSONS.
- ◆ THE HEARTH DOOR MUST ALWAYS BE CLOSED DURING NORMAL FUNCTIONING OF THE PRODUCT.
- ◆ WHEN THE APPLIANCE IS FUNCTIONING AND HOT TO THE TOUCH, ESPECIALLY ALL EXTERNAL SURFACES, ATTENTION MUST BE PAID
- ◆ CHECK FOR THE PRESENCE OF ANY OBSTRUCTIONS BEFORE SWITCHING THE APPLIANCE ON FOLLOWING A PROLONGED PERIOD OF INACTIVITY.
- ◆ THE GENERATOR HAS BEEN DESIGNED TO FUNCTION IN ANY CLIMATIC CONDITION. IN PARTICULARLY ADVERSE CONDITIONS (STRONG WIND, FREEZING) SAFETY SYSTEMS MAY INTERVENE THAT SWITCH THE GENERATOR OFF. IF THIS OCCURS, CONTACT THE TECHNICAL AFTER-SALES SERVICE AND ALWAYS DISABLE THE SAFETY

SYSTEMS.

- ◆ IN THE EVENT THE FLUE CATCHES FIRE, USE SUITABLE SYSTEMS FOR SUFFOCATING THE FLAMES OR REQUEST HELP FROM THE FIRE BRIGADE.
- ◆ THIS APPLIANCE MUST NOT BE USED TO BURN WASTE
- ◆ DO NOT USE ANY FLAMMABLE LIQUIDS FOR IGNITION
- ◆ DURING THE FILLING PHASE DO NOT PUT THE BAG OF PELLETS TO INTO CONTACT WITH THE PRODUCT
- ◆ THE MAJOLICAS ARE TOP QUALITY ARTISAN PRODUCTS AND AS SUCH CAN HAVE MICRO-DOTS, CRACKLES AND CHROMATIC IMPERFECTIONS. THESE FEATURES HIGHLIGHT THEIR VALUABLE NATURE. DUE TO THEIR DIFFERENT DILATION COEFFICIENT, THEY PRODUCE CRACKLING, WHICH DEMONSTRATE THEIR EFFECTIVE AUTHENTICITY. TO CLEAN THE MAJOLICAS, IT IS RECOMMENDED TO USE A SOFT, DRY CLOTH. IF A DETERGENT OR LIQUID IS USED, THE LATTER COULD PENETRATE INSIDE THE CRACKLES, HIGHLIGHTING THEM.
- ◆ SINCE THE PRODUCT CAN TURN ON AUTOMATICALLY THANKS TO THE TIMER, OR REMOTELY USING THE DEDICATED APPLICATIONS, IT IS STRICTLY FORBIDDEN TO LEAVE ANY COMBUSTIBLE OBJECT WITHIN THE SAFETY DISTANCES INDICATED ON THE TECHNICAL DATA PLATE.
- ◆ INTERNAL COMBUSTION CHAMBER PARTS CAN BE SUBJECT TO EXTETICAL WARN, IT DOESN'T AFFECT THE FUNCTIONALITY

ROUTINE MAINTENANCE

Based on Decree 22 January 2008 n°37 art.2, routine maintenance means interventions aimed at reducing degradation due to normal use, as well as dealing with accidental events entailing the need of first interventions, which however do not modify the structure of the system upon which one is intervening or its intended use according to the requirements laid down by the technical standards in force and by the manufacturer's use and maintenance manual.

INSTALLATION

GENERAL

The flue gas exhaust and hydraulic connections must be carried out by qualified personnel who must issue installation conformity documentation compliant with national standards.

The installer must provide the owner or person acting for him, according to the legislation in force, with the declaration of conformity, supplied with:

- 1) the use and maintenance manual of the appliance and of the system components (such as for example, the smoke ducts, chimney, etc.);
- 2) photocopy or photograph of the chimney plaque;
- 3) system booklet (where applicable).

The installer must ask to be issued with a receipt stating that the documentation has been provided, and must keep it with a copy of the technical documentation relating to the installation.

For installation in a condominium, prior approval from the condominium's administrator must be requested.

Where required, check the exhaust gas emissions after installation. Should a sampling point be installed, it must be airtight.

COMPATIBILITY

Do not install in rooms with a fire hazard. It is also forbidden to install it in living areas with the following characteristics:

1. where there are liquid fuel appliances with continuous or discontinuous operation that draw the combustion air into the room in which they are installed.
2. where there are type B gas appliances intended for heating, with or without domestic hot water production and in adjacent and communicating rooms.
3. where the depression measured in situ between the external and internal environment is greater than 4 Pa.

N.B.: Watertight appliances can also be installed in the cases indicated in points 1, 2 and 3 of this paragraph.

INSTALLATIONS IN BATHROOMS, BEDROOMS AND STUDIO FLATS

Installation in bathrooms, bedrooms and studio flats is only allowed for sealed or closed hearth appliances with ducted combustion air taken from the outside.

POSITIONING AND SAFETY DISTANCES

The support surfaces and/or points must have a suitable capacity to bear the overall weight of the appliance, accessories and coverings. If the floor is made of a combustible material, we recommend using a non-combustible material to protect the front part from any burnt material which might fall during routine cleaning operations. The generator must be level to function properly. The side walls, the rear walls and the floor support surface should be made of non-combustible material.

MINIMUM DISTANCES (PELLET STOVES)

Installation next to flammable or heat-sensitive materials is permitted **only if the special safety distances specified on the label at the beginning of the manual (pag.2) are observed**. If the materials are not flammable, you must keep a side and rear distance of at least 100 mm (without the inserts). For products equipped with rear spacers, wall-mounting installation is permitted exclusively for the rear side.

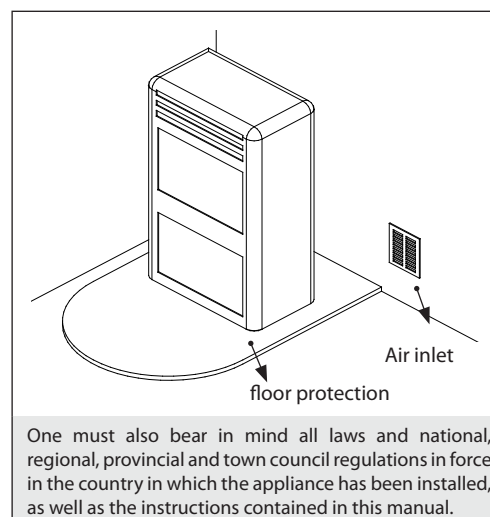

PREPARATIONS FOR MAINTENANCE

To carry out extraordinary maintenance operations on the product, it may be necessary to move it away from the adjacent walls. This must be done by a technician authorised to disconnect the combustion product evacuation ducts and then reconnect them. For heaters connected to the hydraulic system, the connection between the system itself and the product must be made in such a way that, when an authorised technician is about to carry out extraordinary maintenance operations, it is possible to move the heater at least 1 metre away from the adjacent walls.

INSTALLING INSERTS

When installing inserts, access must be prevented to the internal parts of the appliance and it must not be possible to access live parts during extraction operations.

Any wiring, for example the power cable or room probe, must be positioned so as not to be damaged during movement of the insert and must not come into contact with hot parts. If a cavity made of combustible material is installed, we recommend taking all the safety precautions indicated by the installation standards.

VENTILATION AND AERATION OF INSTALLATION ROOMS

In case of non-airtight heater and/or installation, the ventilation must respect the minimum area indicated below (considering the highest value among those provided):

Appliance categories	Reference standard	Percentage of the net opening section with respect to the appliance fumes outlet section	Minimum net opening value of the ventilation duct
Pellet stoves	UNI EN 14785	-	80 cm ²
Boilers	UNI EN 303-5	50%	100 cm ²

Under any condition, including in the presence of extractor hoods and/or of controlled forced ventilation systems, the pressure difference between the generator installation rooms and the outside must always be equal to or less than 4 Pa.

In the presence of type B gas appliances with intermittent operation not intended for heating, they must have their own aeration and/or ventilation opening.

The air inlets must meet the following requirements:

- ♦ they must be protected with grids, metal mesh, etc., but without reducing the net useful section;
- ♦ they must be made so as to make the maintenance operations possible;
- ♦ positioned so that they cannot be obstructed;

The clean and non-contaminated air flow can also be obtained from a room adjacent to that of installation (indirect aeration and ventilation), as long as the flow takes place freely through permanent openings communicating with the outside.

The adjacent room cannot be used as a garage, or to store combustible material or for any other activity with a fire hazard, bathroom, bedroom or common room of the building.

FLUE GAS EXHAUST

The heat generator works in depression and is equipped with an outlet fan for flue gas extraction. There must be a single exhaust system for the generator. Using a flue that is shared with other devices is not allowed.

The components of the flue gas exhaust system must be chosen in relation to the type of appliance to be installed in compliance with:

- ♦ UNI/TS 11278 in the event of metal chimneys, with particular attention to that stated in the specification;
- ♦ UNI EN 13063-1 and UNI EN 13063-2, UNI EN 1457, UNI EN 1806 in the event of non-metallic chimneys.
- ♦ The length of the horizontal section must be minimal and, in any case, no longer than 3 metres, with a minimum upward slope of 3%
- ♦ There must not be more than 4 direction changes including the one due to the use of the "T" element.
- ♦ A "T" fitting with a condensation collection cap must be provided at the base of the vertical section.
- ♦ If the exhaust is not inserted in an existing flue, a vertical section with a windproof end piece is required (UNI 10683).
- ♦ The vertical duct can be inside or outside the building. If the smoke duct is inserted in an existing flue, it must be certified for solid fuel.
- ♦ If the smoke duct is outside the building, it must always be insulated.
- ♦ The smoke ducts must have at least one airtight inlet for flue gas sampling.
- ♦ All the sections of the flue gas duct must be accessible to inspection.
- ♦ Inspection openings must be provided for cleaning.
- ♦ If the generator has a fume temperature lower than 160°C+ ambient temperature caused by the high yield (contact technicians) it MUST be resistant to humidity.
- ♦ A flue system that does not respect the previous points or, in general, that does not comply with the regulations, may cause condensation phenomena inside it.

CHIMNEY CAP

The chimney caps must meet the following requirements:

- ♦ they must have a useful outlet section no less than double that of the chimney/ducted system on which it is installed;
- ♦ they must be adapted in order to prevent the penetration of rain and snow in the chimney/ducted system;
- ♦ they must be built so that, in the event of winds coming from all directions and from any angle, the expulsion of combustion products is in any case ensured;

EXAMPLES OF CORRECT CONNECTION TO THE CHIMNEY

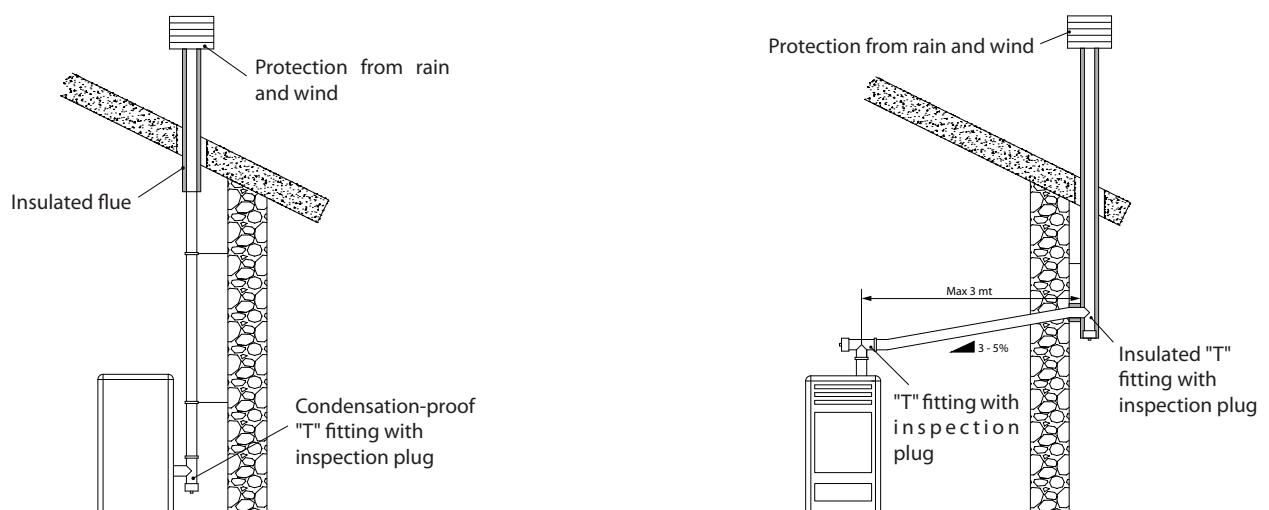

CONNECTION TO THE MAINS ELECTRIC SUPPLY

The generator is supplied with an electric power cable to be plugged into a 230V 50 Hz socket, possibly with a circuit breaker switch. The socket must be easily accessible.

The electrical system must be compliant with standards. The efficiency of the earthing circuit must be checked. Unsuitable earthing of the system can cause malfunctioning for which the manufacturer will not be held liable.

Power supply variations beyond 10% can cause faulty operation of the product.

HYDRAULIC SYSTEM

Certain concepts referring to the Italian Standard UNI 10412-2 (2009) are described in this chapter.

As previously described, when installing, all national, regional, provincial and council Standards in force provided by the country in which the appliance has been installed must be complied with.

During installation of the generator it is MANDATORY to adjust the system with a manometer in order to display the water pressure.

TABLE OF SAFETY DEVICES FOR CLOSED VESSEL SYSTEM AND NOT PRESENT IN THE PRODUCT	
Safety valve	✓
Pump control thermostat (it is managed by the water probe and the board program)	✓
Water temperature indicator (display)	✓
Pressure transducer with display	✓
Automatic circuit breaker adjustment switch (managed by board program)	✓
Pressure transducer with minimum and maximum pressure switch alarm	✓
Water overheating automatic circuit breaker switch (block thermostat)	✓
Circulation system (pump)	✓
Expansion system	✓

Pay attention to the correct sizing of the system:

- ♦ generator power compared to the thermal requirement
- ♦ possible need for a buffer tank

INSTALLATION AND SAFETY DEVICES

The installation, relative system connections, commissioning and inspection of correct functioning must be carried out perfectly, in full compliance with Standards in force, national, regional and municipal, as well as these instructions. For Italy, installation must be carried out by professionally qualified staff (Ministerial Decree dated 22.01.08 n°37).

Extraflame S.p.A. declines all responsibility for damage to objects and/or persons caused by the system.

TYPE OF SYSTEM

- ♦ There are 2 different types of system:
- ♦ Open vessel system and closed vessel system.
- ♦ The product has been designed and made to work with closed vessel systems.

CHECK THAT THE PRELOAD OF THE EXPANSION VESSEL IS SET TO 1.5 BAR.

SAFETY DEVICES FOR CLOSED VESSEL SYSTEM

In accordance with the UNI 10412-2 (2009) regulation in force in Italy, all the closed systems must be fitted with: safety valve, pump control thermostat, temperature indicator, pressure indicator, automatic circuit breaker block switch (block thermostat), circulation system, expansion system, and safety dissipation built-in to the generator with thermal safety valve (self-activated), if the appliance does not have a temperature self-adjustment system.

DETAILS ISIDORA H16 - H20

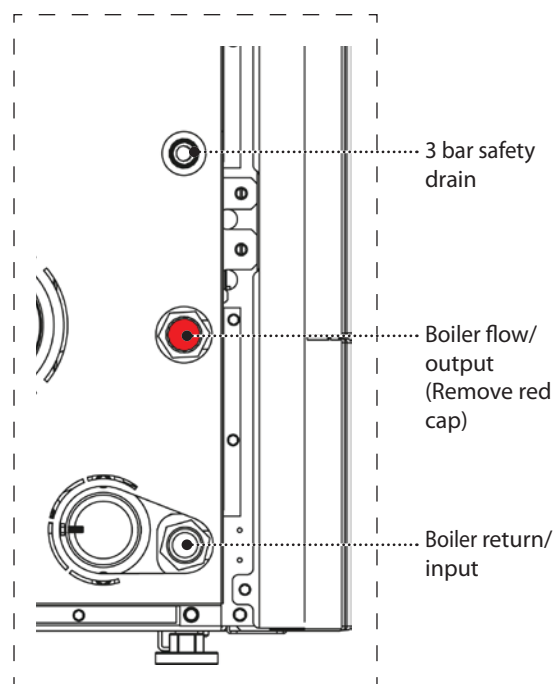
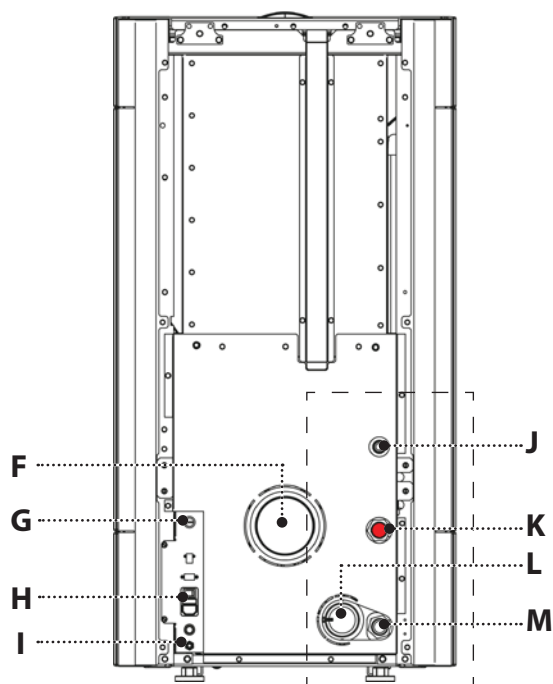
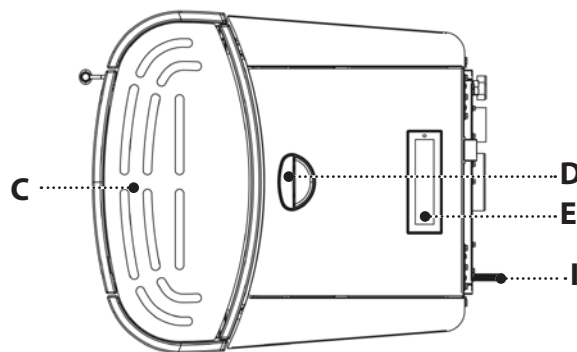
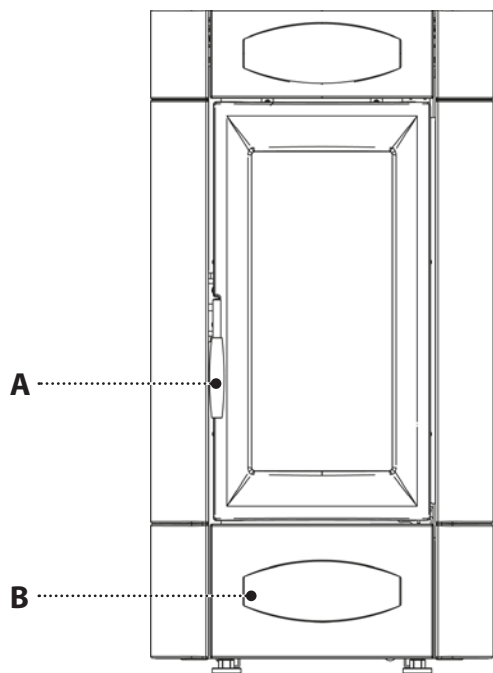

A	Door handle	F	Fumes outlet	J	3 bar safety drain
B	Access to the ash drawer	G	Resetting	K	Boiler flow/output
C	Ambient air outlet	H	On/Off Fuse 230V power supply	L	Combustion air inlet
D	Pellet hopper			M	Boiler return/input
E	Display	I	Ambient probe		

FEATURES	
Water content of the thermo-product heat exchanger (l)	26.7
Volume of expansion vessel integrated into thermo-product (l)	*8
3 bar safety valve integrated into the thermo-product	YES
Minimum and maximum pressure switch integrated into the thermo-product	YES
PWM pump integrated into the thermo-product	YES
Pump max. head (m)	6

* ENVISION ANY INTEGRATIVE EXPANSION VESSEL ON THE BASIS OF THE SYSTEM WATER CONTENT.

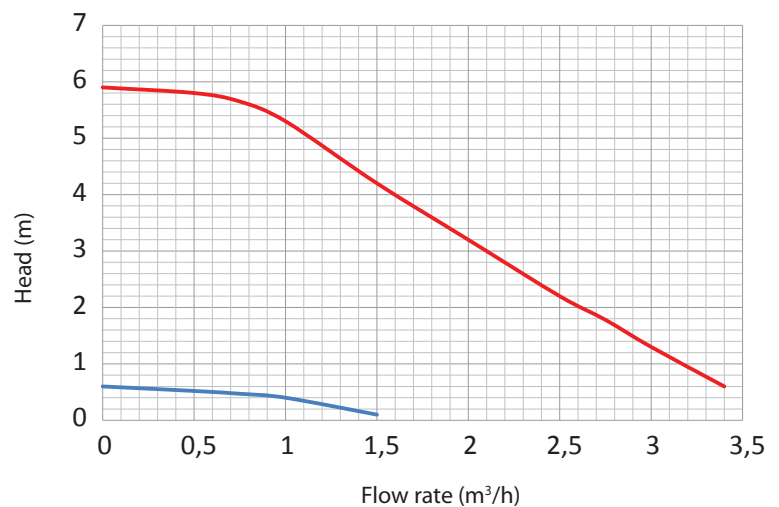

The diagram at the side illustrates the behaviour of the pump used on our thermo-products at the speeds that can be set.

CHECKS AND MEASURES FOR COMMISSIONING

CAUTION!
FOR CORRECT GENERATOR OPERATION, THE HYDRAULIC SYSTEM PRESSURE MUST BE BETWEEN 0.6 AND 2.7 BAR.

If the pressure measured by the digital pressure switch is lower than 0.6 or higher than 2.7 bar, an alarm will be generated. By taking the pressure of the water within standard values, the alarm can be reset by pressing the /1 key for 3 seconds (The alarm can be reset only if the fumes motor has stopped and 15 minutes have passed since the alarm was displayed)

THE PELLET LOAD MOTOR DOES NOT FUNCTION:

It is normal that there is air inside the circuit due to filling the system.

On the 1st ignition cycle, the movement of the water causes the air bubbles to move and be bled by the system automatic venting. This can cause the pressure to drop and the minimum pressure switch to intervene, which interrupts operation of the pellet conveying motor and therefore operation of the heat generator.

The system must be bled several times to eliminate the air and loaded when the pressure is too low.

It is not an anomaly, but normal phenomenon, due to filling. Following filling, the system must always be bled using the relevant vents in the circuit and having the machine perform the "air vent" function. (Following commissioning and with the machine cold, activate the "air vent" function again. - see "SETTINGS" chapter)

BULB THERMOSTATS - RESET

Check by pressing reset, before contacting a technician (see chapter on RESETTING).

STOVE POSITIONING

To ensure the stove works correctly, it should always be positioned so that it is perfectly level, using a spirit level.

NOTE FOR CORRECT OPERATION

The following indications must be respected for correct pellet stove operation:

Both during stove operation and when it is not used, all hatches (pellet hopper, door, ash drawer) must remain closed at all times. They can be opened only for the time required to load the fuel and for maintenance.

"CLOSE HOPPER - STOVE DOOR"

This indication means that you have 60" to close the hatch/door and the pellet lid.

If not, during ignition the stove will go into "DEPR ALARM" mode, while during normal operation the stove will go into "COOLING - WAITING TIME" mode and then re-start automatically when the correct conditions are present (stove cold, etc.).

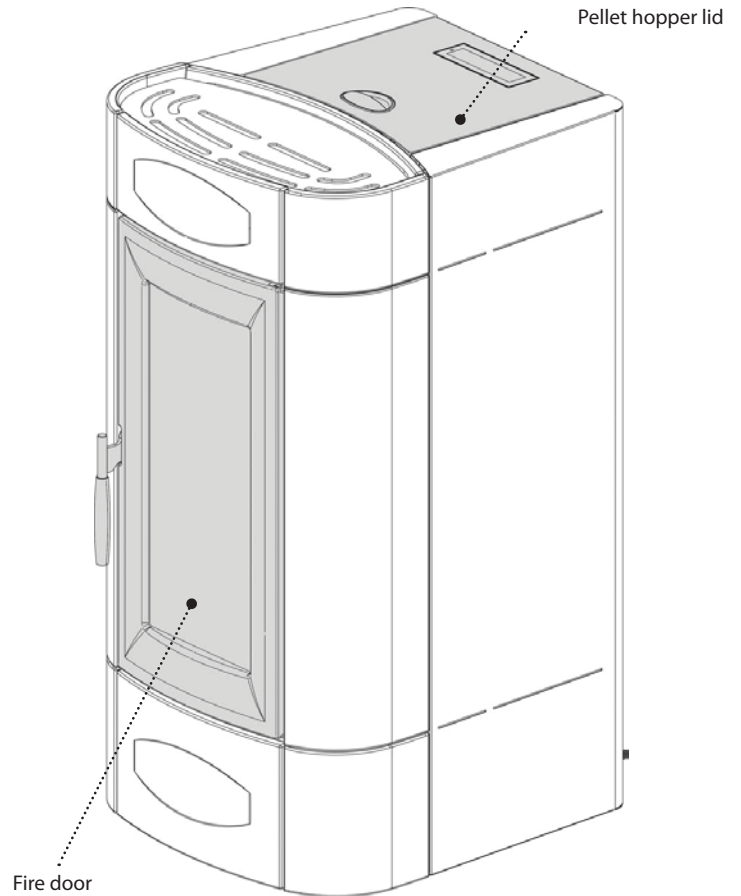

RESETTING

The figure below shows the reset position (95°C). It is recommended to contact the qualified technician if one of the resets should be triggered, so as to verify the cause.

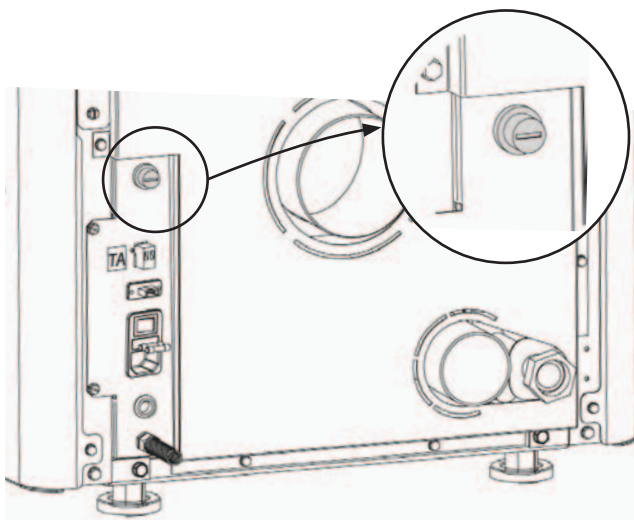

FUSE

If there is no power supply to the stove, check the state of the fuse located in the box between the stove switch and the power cord connection.

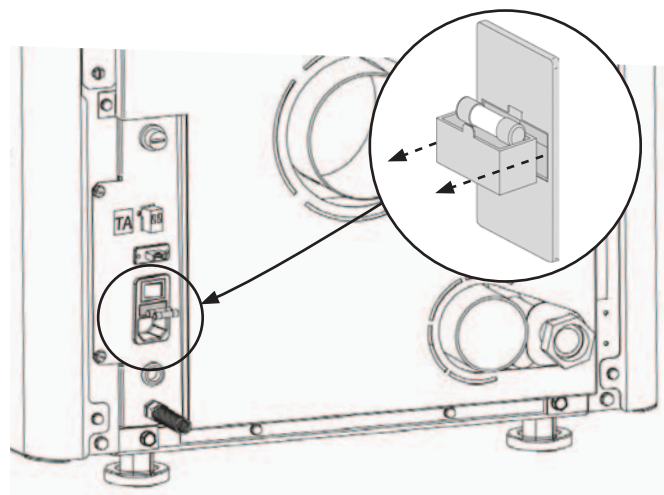

PELLETS AND FEEDING

Pellets are made by subjecting wood shavings i.e. the rejects of pure wood (without paint) sawmill, carpenter products and products from other activities connected to working and transforming wood, to very high pressures.

This type of fuel is fully ecological as no glues are used to hold it together. Indeed, the compactness of the pellets over time is guaranteed by a natural substance found in wood: lignite.

As well as being an ecological fuel, as wood residues are made the most of, the pellet also has technical advantages.

While wood has a calorific value of 4.4 kWh/kg. (with 15% humidity, thus after 18 months of seasoning), the calorific value of the pellet is 5 kWh/kg.

Pellet density is about 650 kg/m³ and water content is equal to 8% of its weight. For this reason the pellets do not need to be seasoned in order to obtain a sufficiently adequate heat yield.

The pellets used must comply with the characteristics described by the following standards:

EN PLUS class A1, ISO 17225-2 class A1

and

UNI EN 303-5 with the following characteristics: water content ≤ 12%, ash content ≤ 0.5% and lower calorific value >17 MJ/kg (in the case of boilers).

The manufacturer always recommended using pellets with a diameter of 6 mm with its products.

PELLET STORAGE

In order to ensure problem-free combustion pellets must be stored in a dry place.

Open the tank lid and load the pellets using a scoop.

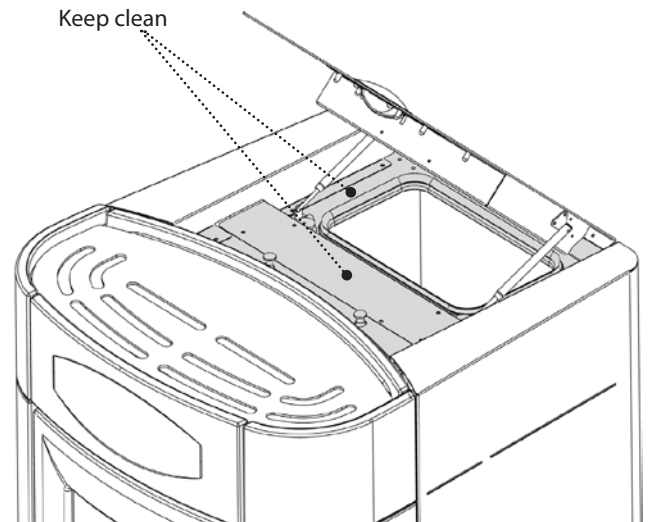

THE USE OF POOR QUALITY PELLETS OR ANY OTHER MATERIAL DAMAGES THE FUNCTIONS OF THE GENERATOR AND MAY INVALIDATE THE WARRANTY AND FREE THE MANUFACTURER FROM RESPONSIBILITY.

PELLET HOPPER - PRESSURISED CLOSURE.

During stove operation, the pellet hopper lid must always be closed.

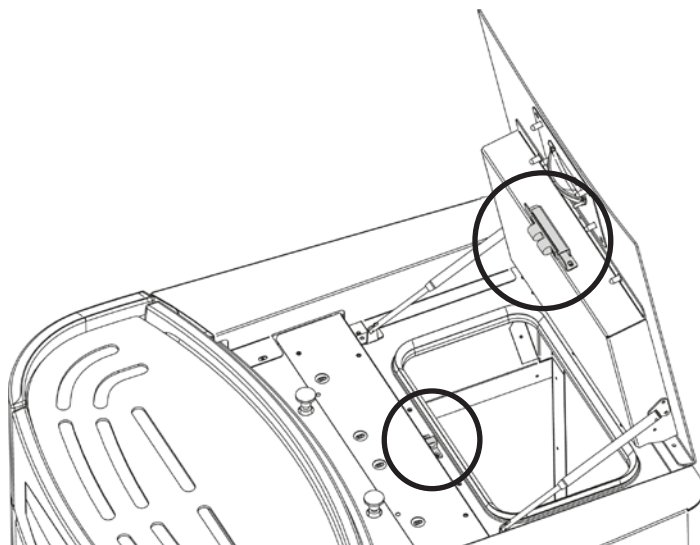

DO NOT PLACE THE BAG DIRECTLY ON THE STOVE TO LOAD THE TANK. ALWAYS USE A SCOOP TO LOAD THE TANK. DO NOT RUB OR PLACE WEIGHTS ON THE TANK SEAL. KEEP THE TANK COVER SEAL SUPPORTING SURFACE CLEAN AT ALL TIMES. CHECK THE CONDITIONS OF THE SEAL FREQUENTLY. IF DAMAGED, CONTACT YOUR LOCAL AUTHORISED TECHNICIAN.

REMOTE CONTROL



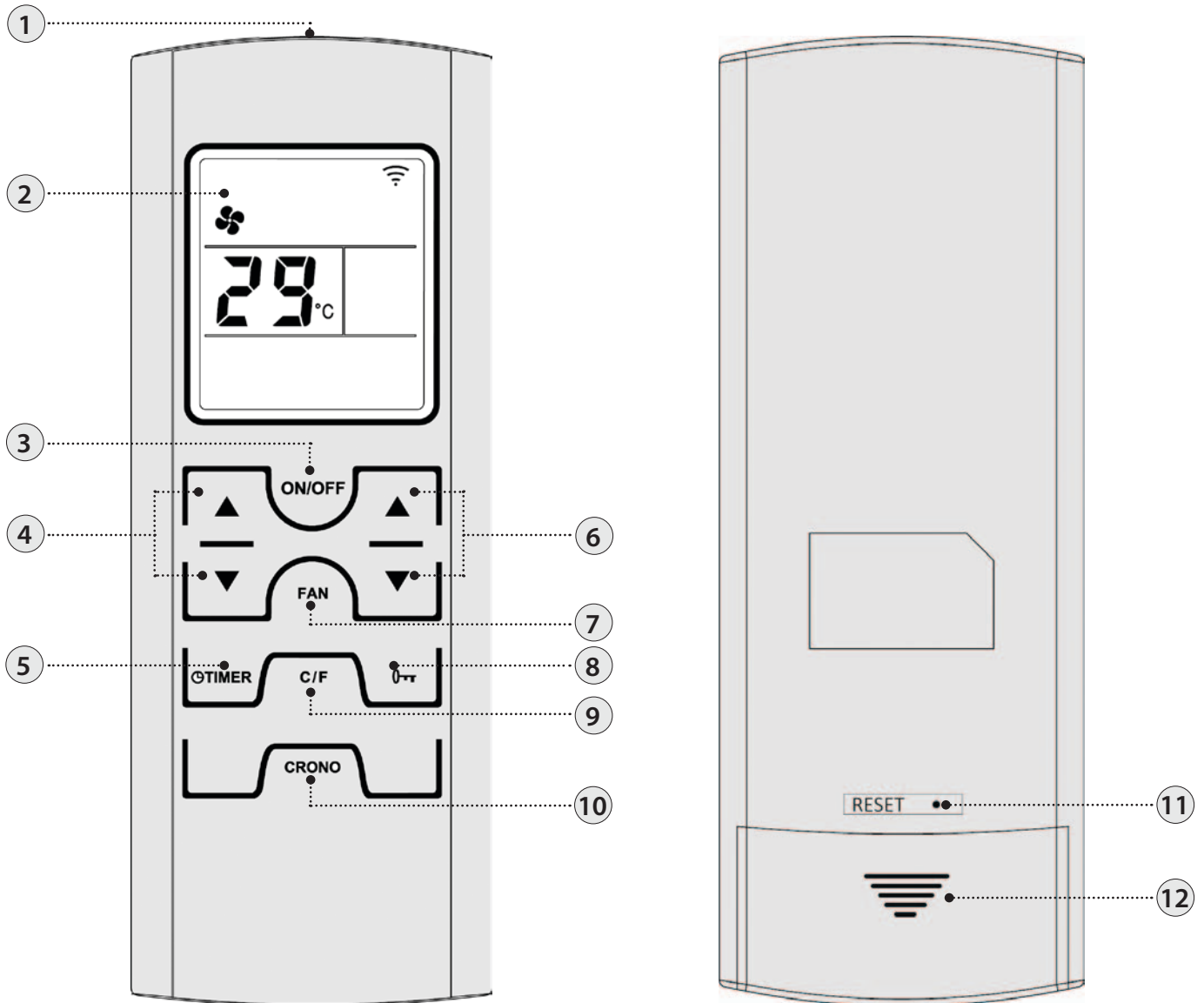



The remote control can be used to adjust the main stove functions.



1	Transmitter	7	Select air mode*
2	Display	8	Lock keyboard
3	On/off stove (hold for 3 seconds)	9	Degrees Celsius / Fahrenheit
4	Set power	10	Press the button once to enable or disable the chrono
5	Set switch-off delay: The button allows to set the switch-off delay. For example, if you set it to one hour, the stove will automatically switch off after the set time *	11	Reset*
6	Set room temperature	12	Battery compartment

* not available in this model

REMOTE CONTROL ICONS

	Air mode selected: * Flashing COMFORT On AUTO		Enable chrono Light on = activated Light off = deactivated
OFF TIME 	Set switch-off delay *		Indicates the transmission of the radio signal On = during all radio communication Off = radio communication absent
	Battery low		Keys locked
	Set power level. The power level is displayed, instead of the set room temperature, for 3 seconds when one of the set power buttons is pressed (4).		

INSERTING THE BATTERIES

Remove the battery compartment cover by sliding it down. Insert 2 AAA batteries.

Insert the batteries respecting the correct polarity (+) and (-).
Close the cover of the battery compartment.

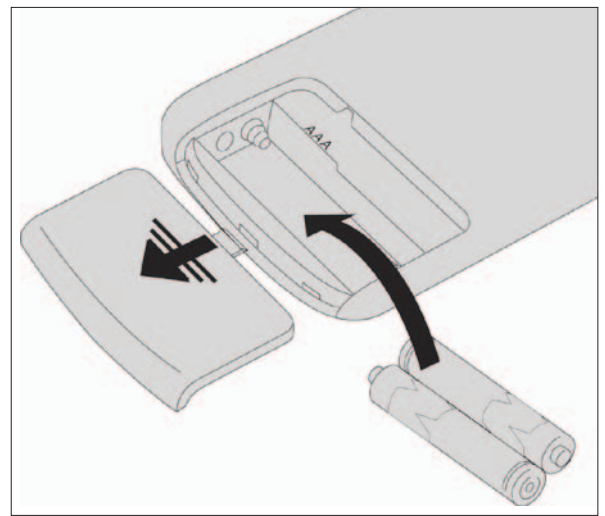

IF THE REMOTE CONTROL IS SWITCHED OFF DUE TO NO BATTERY INSTALLED, THE STOVE CAN BE CONTROLLED FROM THE COMMAND PANEL LOCATED ON THE UPPER PART OF THE STOVE. WHEN CHANGING THE BATTERIES, MAKE SURE YOU FOLLOW THE SYMBOLS PRINTED INSIDE THE REMOTE CONTROL.



Respect the environment!

Used batteries contain metals that are harmful to the environment, and therefore must be disposed of separately in special containers.

ADVICE AND PRECAUTIONS FOR THE USE OF THE REMOTE CONTROL

- ◆ Remove the batteries if it is not used for a long time.
- ◆ When being used, direct it towards the stove's signal receiver.
- ◆ Handle the remote control with care. When it is not being used, place it on the special base supplied.
- ◆ The remote control must not be left in a place where it is exposed to direct sunlight or near a source of heat.
- ◆ The quality of the signal may be affected by other IR sources.



THE REMOTE CONTROL IS FITTED WITH AN LCD BACKLIT DISPLAY. THE BACKLIGHTING LASTS 20 SECONDS FROM THE LAST PRESS OF A BUTTON. AFTER A CERTAIN TIME, TO SAVE BATTERY POWER, THE DISPLAY TURNS OFF (ENERGY SAVING MODE).

THE CONTROL FUNCTIONS ARE REACTIVATED WHEN THE REMOTE IS REMOVED FROM ITS UNIT OR BY A LONG PRESS OF THE BUTTON.

* Not available in this model

TOUCH SCREEN DISPLAY

The stove is equipped with a modern touch screen display with Wi-Fi technology that allows for the individual functions of the unit to be adjusted by the user in an easy and intuitive manner.

Touch the buttons (icons) on the display to activate the actions. The touch screen display reacts with the touch of your fingers.

CAUTION!

- ◆ Do not use screen protectors: the display might not work properly
- ◆ Do not place the touch screen display in direct or indirect contact with water. The touch screen display may not work properly in the presence of humidity or if it is exposed to water.
- ◆ To avoid damaging the touch screen display, do not touch it with sharp objects and do not press it too hard with your fingers.
- ◆ During opening and closure, press only on the outer frame of the Display.

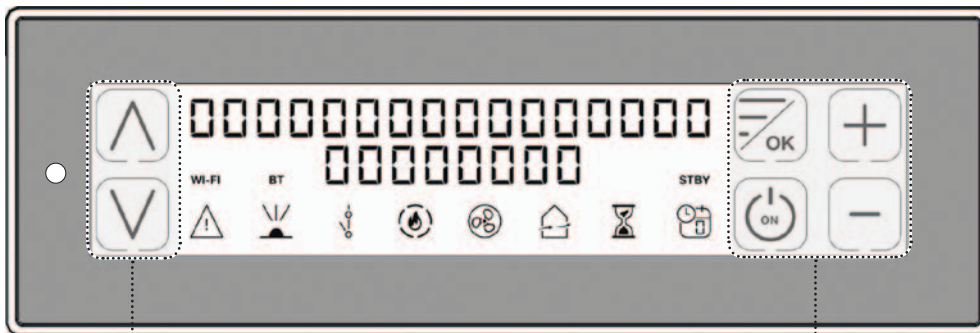

TOUCH SENSITIVE PARTS



OPENING THE DISPLAY

Unlock the display by pressing on the edges of the display (A). Lift the display until you hear a "click".

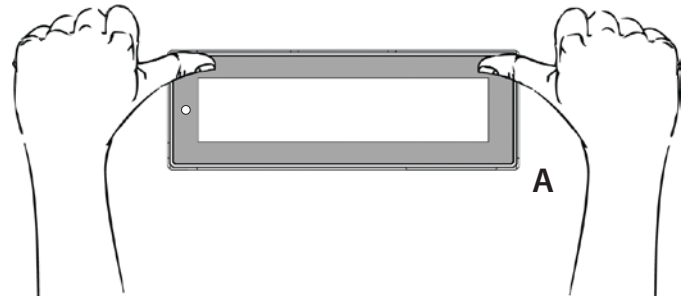

CLOSING THE DISPLAY

Unlock the display by moving the lever on the back of the display (B). Lower the display as shown in figure (A) until it is completely closed.

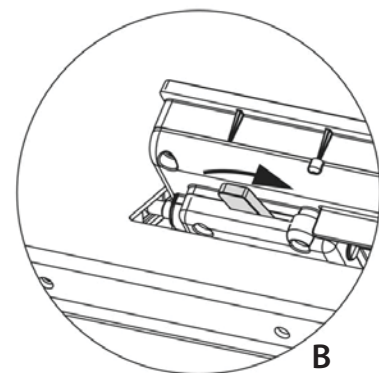
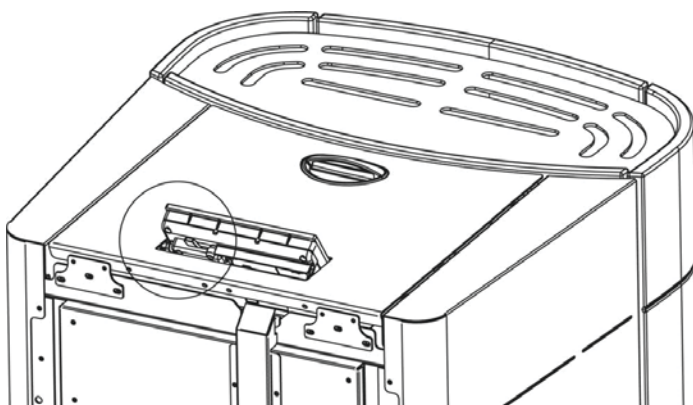

FREQUENCY BANDS	MAXIMUM POWER TRANSMITTED
Wi-Fi	20.0 DBM
BLUETOOTH	Class-3

CONTROL BOARD

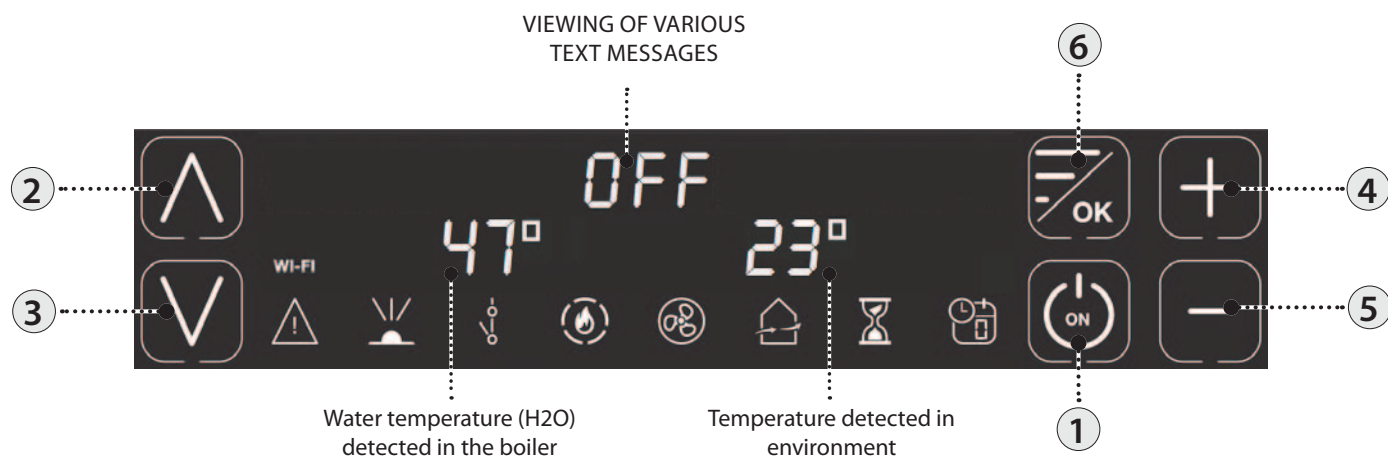

- ① On/off stove.

- ② Increase operating power / scroll through the menus.

- ③ Decrease operating power / scroll through the menus.

- ④ Increase operating set thermostat / Change data in the menus.

- ⑤ Decrease operating set thermostat / Change data in the menus.

- ⑥ To access the menu / confirm key.

ICON KEY			
	Indicates the presence of an alarm. Off: indicates there are no alarms On: indicates the presence of an alarm		Indicates the weekly programming status Off: deactivated. On: activated. The number indicates the current reference time frame.
	Indicates the reception of the IR signal On = IR command received Off = IR communication absent	WI-FI	Wi-Fi icon Off: deactivated. On: activated and connected to the home network. Flashing: activated but not connected to the home network.
	Indicates contact of the external additional thermostat Closed contact: the contact of the external additional thermostat is closed. Open contact: the contact of the external additional thermostat is open.	STBY	STAND-BY function icon Off: deactivated. On: activated.
	Indicates the stove power. Flame on: stable power. Flame flashing: the power is changing. The dashes indicate the actual power of the machine.		It indicates the operation of the pump. Off = pump stopped. On = pump active. Flashing = electronic anti-condensation function active.
	It indicates the operation of the tangential fan. Off = ventilation not active. On = ventilation active.		Not in use

GENERAL MENU



- ① Go back - exit
- ② ③ Scroll parameters: next (3); previous (2)
- ④ ⑤ Modify data settings: increase (4); decrease (5)
- ⑥ Confirm - access menu

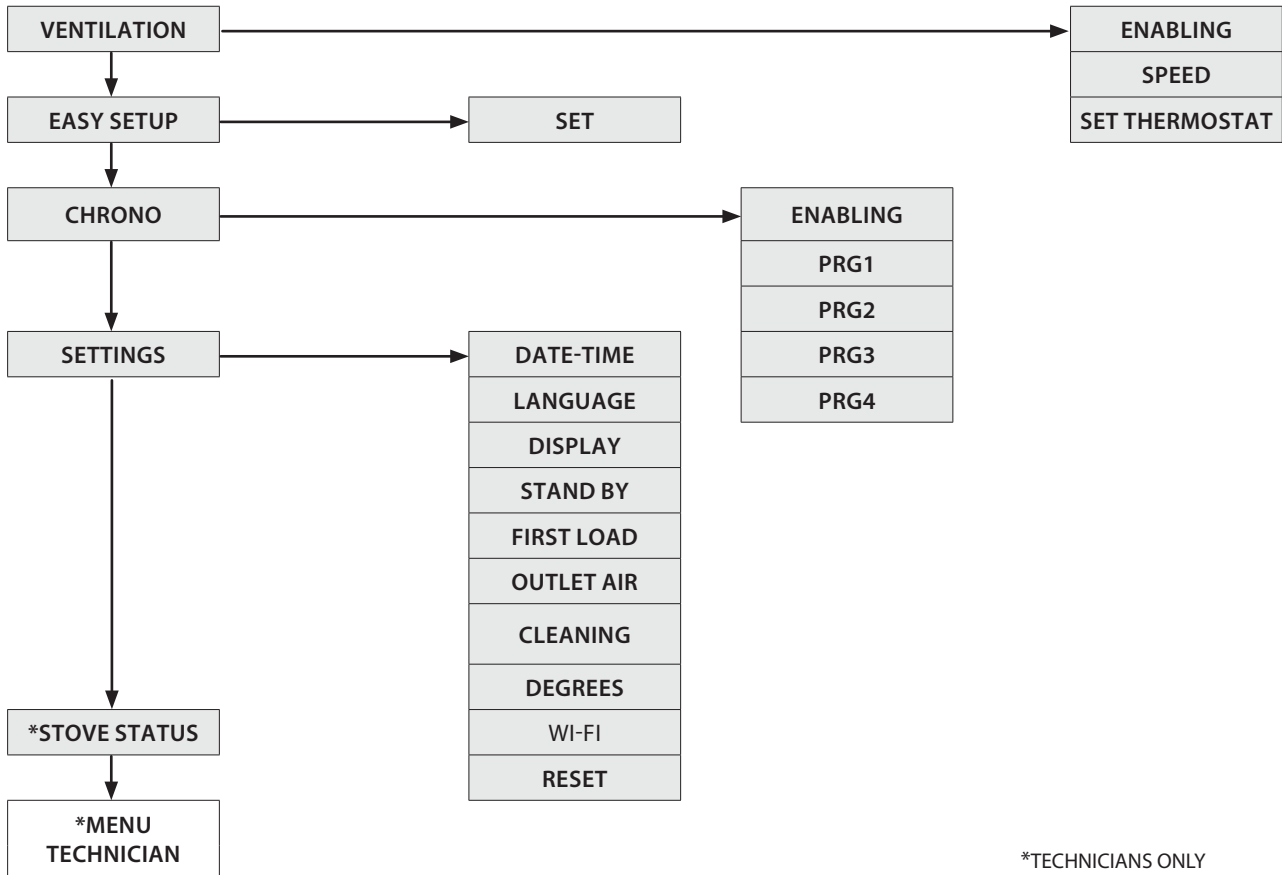

*TECHNICIANS ONLY

GENERAL WARNINGS

Advice to follow for the first start-ups of the product:

During the first hours of operation, there may be some smoke or odours, but they are due to the normal "thermal break-in" process. During this process, the duration of which changes depending on the product, it is recommended to:

- ♦ Ventilate the room well
- ♦ If present, remove any majolica parts from the top of the product
- ♦ Activate the product at the maximum power and temperature
- ♦ Avoid remaining in the room for a long time
- ♦ Do not touch the surfaces of the product

Notes:

The process is completed after a few heating/cooling cycles. Do not use for the combustion of elements or substances other than those indicated in the manual.

Before turning on the product, it is necessary to perform the following checks:

- ♦ If it is intended to be connected to a hydraulic system, it must be complete and fully functional and in compliance with the instructions given in the product manual and with the relevant regulations in force.
- ♦ The pellet hopper must be completely loaded
- ♦ The combustion chamber and the burn pot must be clean
- ♦ Make sure that the fire holder, the ash pan and the pellet hopper close hermetically (if present in the hermetic version); they must be closed and there must be no foreign bodies in the sealing elements and gaskets.
- ♦ Check that the power cord is properly connected
- ♦ The bipolar switch (if present) must be set to position "1".



MAKE SURE THAT THERE ARE NO RESIDUES OR DIRT IN THE BURN POT. THE HOLES AT THE BOTTOM OF THE BURN POT MUST BE COMPLETELY FREE TO GUARANTEE PROPER COMBUSTION. THE "EASY SETUP" FUNCTION CAN BE USED TO ADAPT COMBUSTION BASED ON THE DESCRIBED NEEDS.

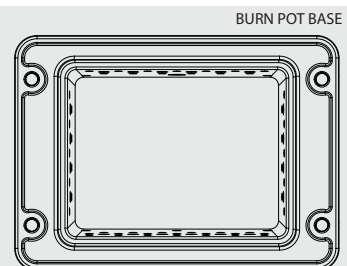

FIRST IGNITION SETTINGS

Once the power cord at the back of the stove has been connected, move the switch, also located on the back, to (I).

The switch at the back of the stove powers the stove board.

The stove remains off and a first screen appears on the panel reading OFF .

DATE-TIME

This menu allows the date and time to be set.

CONTROLS PROCEDURE

- ◆ Press key 6.
- ◆ Press key 3 until **SETTINGS** appears and confirm by pressing key 6.
- ◆ Confirm **DATE-TIME** by pressing key 6 and using keys 4 and 5 to set the day.
- ◆ Continue by pressing key 6.
- ◆ Use the same procedure with 4 or 5 to choose the setting and 6 to move continue, to set the hour, minutes, date, month and year.
- ◆ Press key 6 to confirm and key 1 to scroll back through the menus until the initial page.

LANGUAGE

This menu allows the preferred language to be selected.

The available languages are: Italian - English - German - French - Spanish - Portuguese - Danish - Estonian - Croatian - Slovenian - Dutch - Polish.

CONTROLS PROCEDURE

- ◆ Press key 6.
- ◆ Press key 3 until **SETTINGS** appears and confirm by pressing key 6.
- ◆ Press key 3 until **LANGUAGE** appears and confirm by pressing key 6.
- ◆ Select the language using keys 4 or 5.
- ◆ Press key 6 to confirm and key 1 to scroll back through the menus until the initial page.

DEGREES

This menu allows you to set the unit of measure for the temperature. The value is preset to °C.

CONTROLS PROCEDURE

- ◆ Press key 6.
- ◆ Press key 3 until **SETTINGS** appears and confirm by pressing key 6.
- ◆ Press key 3 until **DEGREES** appears and confirm by pressing key 6.
- ◆ Use keys 4 -5 to select Celsius or Fahrenheit.
- ◆ Press key 6 to confirm and key 1 to scroll back through the menus until the initial page.



DO NOT USE ANY FLAMMABLE LIQUIDS FOR IGNITION!
DO NOT ALLOW THE BAG OF PELLETS TO COME INTO CONTACT WITH THE BOILING HOT STOVE DURING THE FILLING PHASE!
IN THE EVENT OF CONTINUED FAILURE TO LIGHT, CONTACT AN AUTHORISED TECHNICIAN.



NO IGNITION

THE APPLIANCE MAY FAIL TO LIGHT BECAUSE THE AUGER IS EMPTY AND NOT ALWAYS ABLE TO LOAD THE BURN POT FAST ENOUGH WITH THE PELLETS NEEDED FOR NORMAL IGNITION. IF THE PROBLEM OCCURS AFTER ONLY A FEW MONTHS OF OPERATION, CHECK THAT THE ROUTINE CLEANING DESCRIBED IN THE STOVE HANDBOOK HAS BEEN CARRIED OUT CORRECTLY

OPERATION AND LOGIC

IGNITION

Once the points listed previously have been checked, press key 1 for three seconds to ignite the stove. 15 minutes are available for the ignition phase. After ignition and having reached the control temperature, the stove interrupts the ignition phase and passes to STARTING.

PREPARATION

During the start-up phase, the stove stabilises combustion, increasing it progressively, to then start ventilation and pass on to WORK.

WORK

During the work phase, the stove reaches the set power set; see following item.

SET POWER

Set the operating power from 1 to 5 (using keys 2 and 3).

Power 1 = minimum level - Power 5 = maximum level.

SET H2O

Set the boiler temperature from 65 to 80°C (using keys 4 and 5).

PUMP OPERATION

The pump is activated when the internal water temperature reaches 60°C. Since the pump is always in operation above 60°C, it is advisable to keep a heating area always open so that the product operates in a more homogeneous manner and in order to prevent stoppages due to overtemperature. This area is usually called "safety area"

CLEANING

At preset intervals, the generator cleans the burn pot, turning the machine off.

When the cleaning phase is finished, the generator will re-start automatically and continue the working phase, returning to the selected power level.

BLOW

During the working phase, the stove has an internal timer, which after a pre-set period of time cleans the burn pot.

This phase is shown on the display, it lowers the stove power level and increases the flue gas exhaust motor for a programmed period of time.

When the cleaning phase is finished, the stove will re-start automatically and continue the working phase, returning to the selected power level.

MODULATION and H-OFF

As the water temperature approaches the set point, the boiler starts to modulate automatically bringing itself to the minimum power. If the temperature increases beyond the set point, it will automatically switch off indicating H-OFF, and will automatically go back on when the temperature drops below the set point.

SWITCH-OFF

Press key 1 for three seconds.

Once this operation has been performed, the appliance automatically enters the switch-off phase, blocking the supply of pellets.

The flue gas exhaust motor and the hot air flow motor will remain on until the stove temperature has dropped below the default parameters.

REIGNITION

The stove can only be re-ignited automatically or manually when the cooling cycle conditions and the preset timer have been satisfied.



IT IS PROHIBITED TO USE THE APPLIANCE WITHOUT THE PARTITION AND/OR FLAME GUARD (SEE FIGURE ON SIDE). REMOVAL WILL COMPROMISE THE SAFETY OF THE PRODUCT AND RESULT IN THE IMMEDIATE NULLIFICATION OF THE WARRANTY PERIOD. IN THE CASE OF WEAR OR DETERIORATION, REQUEST AFTER-SALES ASSISTANCE TO REPLACE THE PART (REPLACEMENT IS NOT COVERED BY THE WARRANTY AS THE COMPONENT IS SUBJECT TO WEAR).

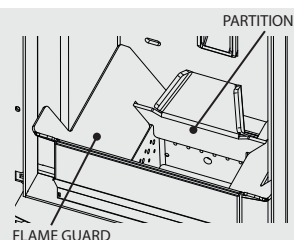

STAND-BY - ADDITIONAL THERMOSTAT

N.B. : INSTALLATION MUST BE PERFORMED BY AN AUTHORISED TECHNICIAN

It is possible to control the temperature of a room adjacent to the room where the stove is positioned; simply connect a thermostat following the procedure described in the following section (it is advisable to place the optional mechanical thermostat at a height off the ground equal to 1.50 m). Stove operation with the external thermostat connected in the clamp TA can be different depending on the activation or deactivation of the STAND-BY function.

By factory default, the clamp TA is jumpered, therefore it always has closed contact (on request).

ADDITIONAL THERMOSTAT FUNCTIONING WITH STAND-BY ACTIVE

When the STAND-BY function is active, the STBY icon will be on. When the contact or external thermostat is not satisfied (open contact / temperature reached), the stove will switch off. As soon as the contact or external thermostat switches to the "not satisfied" status (closed contact / temperature to be reached) it will re-ignite.

NB: stove operation depends on the temperature of the water inside the stove and relative factory setting restrictions. If the stove is in H-OFF (water temperature reached), any additional contact or thermostat request will be ignored.

ADDITIONAL THERMOSTAT OPERATION WITH STAND-BY DEACTIVATED

When the STAND-BY function is not active, the STBY icon will be off.

When the contact or external thermostat is satisfied (open contact / temperature reached), the stove will go to minimum. As soon as the contact or external thermostat switches to the "not satisfied" status (closed contact / temperature to be reached) the stove will start to work again at the pre-set power.

NB: stove operation depends on the temperature of the water inside the stove and relative factory setting restrictions. If the stove is in H-OFF (water temperature reached), any additional contact or thermostat request will be ignored.

ADDITIONAL THERMOSTAT INSTALLATION

- ♦ Switch the appliance off using the master switch positioned on the rear of the stove.
- ♦ Remove the plug from the socket.
- ♦ Refer to the wiring diagram and connect the two thermostat wires in the relevant terminals located on the back of the stove, one red and one black (clamp TA). **In each model, the position or colour of the terminals may be different. The picture is for illustrative purposes only.**



TO ACTIVATE STAND-BY, REFER TO THE "SETTINGS" CHAPTER

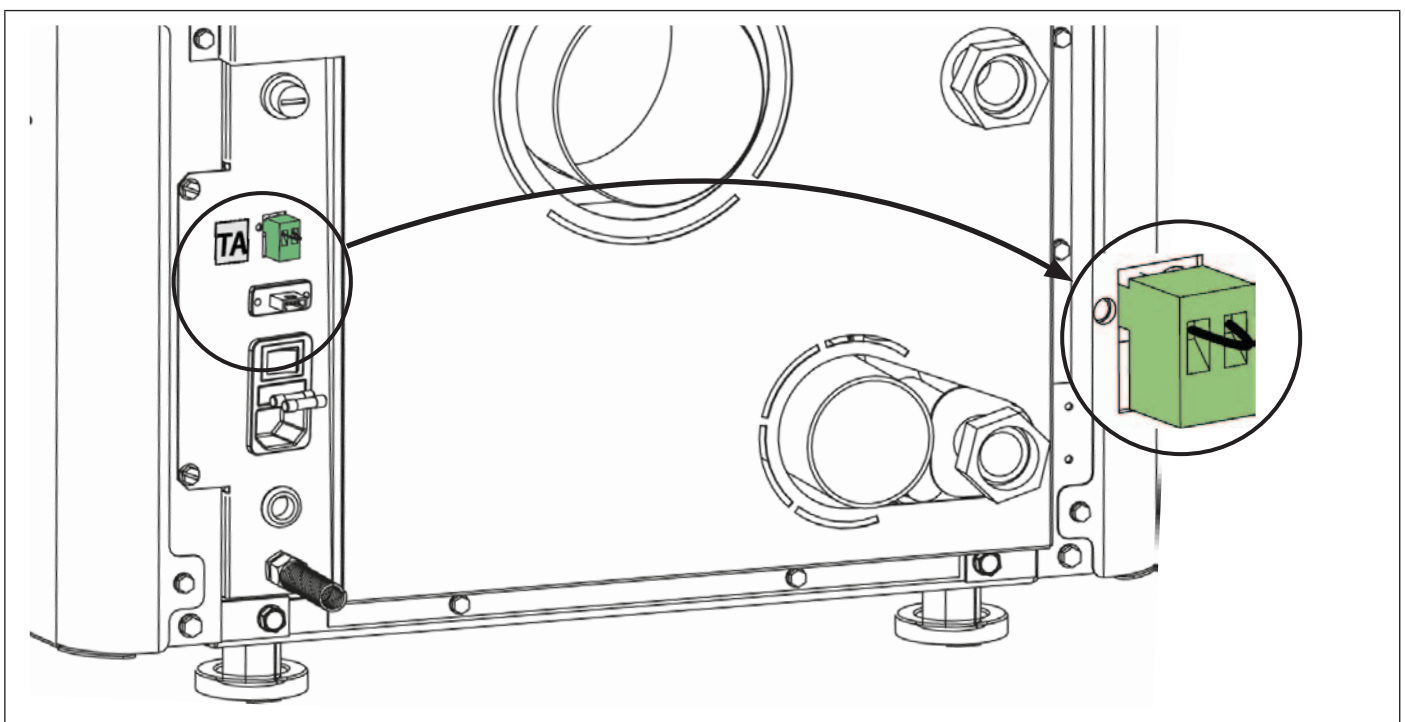

VENTILATION

The menu allows you to enable and adjust the speed (-2, -1, 0, +1, +2) of the front fan.

ENABLING CONTROLS PROCEDURE

- ◆ Press key 6.
- ◆ Press 3 until **VENTILATION** appears and confirm by pressing 6.
- ◆ Confirm **ENABLING** by pressing 6.
- ◆ Use keys 4 -5 to enable (**ON**) or disable (**OFF**) and confirm by pressing 6.
- ◆ Press 1 to return to the previous menus to the initial state.

SPEED ADJUSTMENT CONTROLS PROCEDURE

- ◆ Press key 6.
- ◆ Press 3 until **VENTILATION** appears and confirm by pressing 6.
- ◆ Keep pressing key 3 until **SPEED** appears and confirm by pressing key 6.
- ◆ Use keys 4 -5 to adjust the speed (-2, -1, 0, +1, +2) and confirm by pressing 6.
- ◆ Press 1 to return to the previous menus to the initial state.

SET THERMOSTAT CONTROLS PROCEDURE

- ◆ Press key 6.
- ◆ Press 3 until **VENTILATION** appears and confirm by pressing key 6.
- ◆ Keep pressing 3 until **SET THERMOSTAT** appears and confirm by pressing 6.
- ◆ Use keys 4 5 to adjust the room temperature (7°C - 37°C) and confirm by pressing 6.
- ◆ Press 1 to return to the previous menus to the initial state.

EASY SETUP

The volumetric weight of the pellet is the ratio between the weight and the volume of the pellet. This ratio may change without altering pellet quality. By using the EASY SETUP function, it is possible to change the calibration of the volumetric weight by increasing or decreasing the preset values.

In the stove program, the available values range from “- 3” to “+ 3”; all stoves are calibrated during production with the optimal value, which is 0.

If there is an excessive deposit on the burn pot, access the EASY SETUP program and lower the value to “- 1”; then wait until the next day and if there is no improvement, lower it again down to a limit value of “- 3”.

Instead, if it is necessary to increase the calibration of the volumetric weight of the pellet, change the factory value from “0” to “+ 1, + 2, + 3” as required.

EXCESSIVE PELLETT DEPOSIT IN BURN POT			NORMAL OPERATION	MINIMUM PELLETT DEPOSIT IN BURN POT		
-3	-2	-1	0	+1	+2	+3
THIRD DECREASE RANGE IF THE FIRST TWO ARE INSUFFICIENT	SECOND DECREASE RANGE IF THE FIRST IS INSUFFICIENT	FIRST DECREASE RANGE (TEST FOR 1 DAY)	OPTIMAL FACTORY VALUE	FIRST INCREASE RANGE	SECOND INCREASE RANGE IF THE FIRST IS INSUFFICIENT	THIRD INCREASE RANGE IF THE FIRST TWO ARE INSUFFICIENT

CONTROLS PROCEDURE

- ◆ Press key 6.
- ◆ Press key 3 until **EASY SETUP** appears and confirm by pressing key 6.
- ◆ Use keys 4 -5 to set the range.
- ◆ Press key 6 to confirm and key 1 to scroll back through the menus until the initial page.

N.B.: IF THESE ADJUSTMENTS DO NOT SOLVE THE PROBLEM OF PELLETT DEPOSITS IN THE BURN POT, PLEASE CONTACT YOUR LOCAL SERVICE CENTRE.

CHRONO



This function allows stove ignition and switch-off to be automatically programmed.

The factory setting for CHRONO is off.

The chrono allows the programming of 4 time slots per day, which can be used every day of the week.

For each time slot, it is possible to set ignition and switch-off times, specific days of application, desired temperature and set power. Current day and time settings are essential for the correct operation of the Chrono.

Recommendations

Before using the chrono function, you must set the current day and time, so check that you have followed the points listed in the sub-chapter "DATE-TIME". To use the chrono function correctly, it must not only be programmed, but also enabled. The 4 time slots can be overlapped using the ignition and switch-off time settings. In this way, it is possible to create a combination of time slots with different temperatures and power levels, without changing the status of the stove.

N.B.: in the case of overlapping time slots, the stove will remain on until the last switch-off time.

ENABLING/DISABLING THE CHRONO

CONTROLS PROCEDURE

- ◆ Press key 6.
- ◆ Press 3 until **CHRONO** appears and confirm by pressing key 6.
- ◆ Confirm **ENABLING** by pressing 6.
- ◆ Use keys 4 -5 to enable (**ON**) or disable (**OFF**)
- ◆ Press key 6 to confirm and key 1 to scroll back through the menus until the initial page.

CHRONO	>	ENABLING	>	PRG1	On/off	Enable/disable PRG 1
		∨		PRG2	On/off	Enable/disable PRG 2
		∨		PRG3	On/off	Enable/disable PRG 3
		∨		PRG4	On/off	Enable/disable PRG 4
		PRG1	>	START PRG1	OFF-00:00	PRG1 ignition time
		∨		STOP PRG1	OFF-00:00	PRG1 switch-off time
		∨		MONDAY...SUNDAY	On/off	Enable/disable days PRG1
		∨		SET PRG1	65°C - 80°C (149°F - 176°F)	SET H2O PRG1
		∨		POWER PRG1	1-5	Set power PRG1
		PRG2	>	START PRG2	OFF-00:00	Ignition time PRG2
		∨		STOP PRG2	OFF-00:00	Switch-off time PRG2
		∨		MONDAY...SUNDAY	On/off	Enable/disable days PRG2
		∨		SET PRG2	65°C - 80°C (149°F - 176°F)	SET H2O PRG2
		∨		POWER PRG2	1-5	Set power PRG2
		PRG3	>	START PRG3	OFF-00:00	Ignition time PRG3
		∨		STOP PRG3	OFF-00:00	Switch-off time PRG3
		∨		MONDAY...SUNDAY	On/off	Enable/disable days PRG3
		∨		SET PRG3	65°C - 80°C (149°F - 176°F)	SET H2O PRG3
		∨		POWER PRG3	1-5	Set power PRG3
		PRG4	>	START PRG4	OFF-00:00	Ignition time PRG4
				STOP PRG4	OFF-00:00	Switch-off time PRG4
				MONDAY...SUNDAY	On/off	Enable/disable days PRG4
				SET PRG4	65°C - 80°C (149°F - 176°F)	SET H2O PRG4
				POWER PRG4	1-5	Set power PRG4



IF WEEKLY PROGRAMMER IS ACTIVE ON THE COMMAND PANEL, A SMALL ICON IS DISPLAYED



EXAMPLE OF CHRONO OVERLAPPING TIMES/SLOTS

TIME SLOT

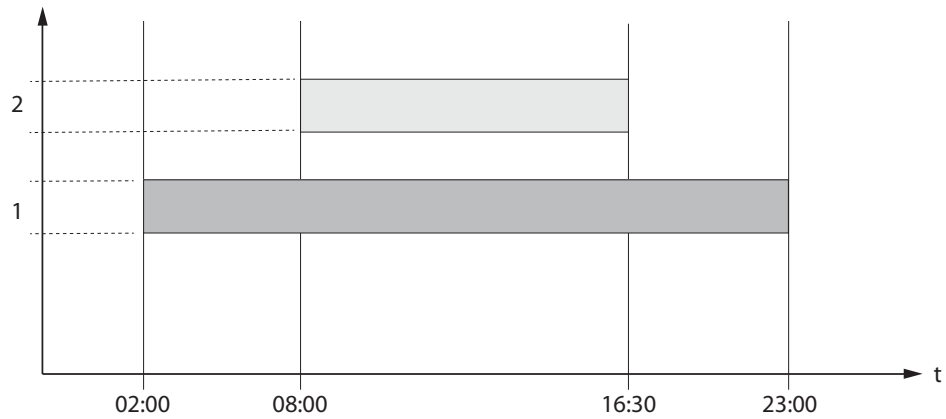

SET POWER

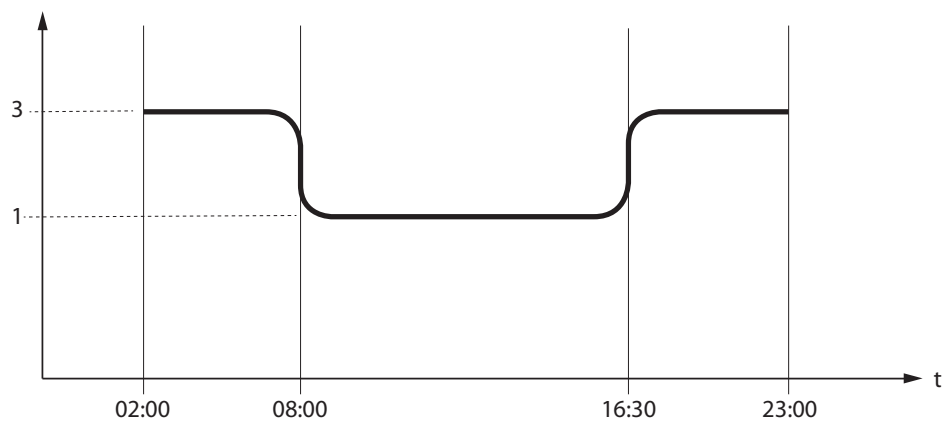

SET H2O

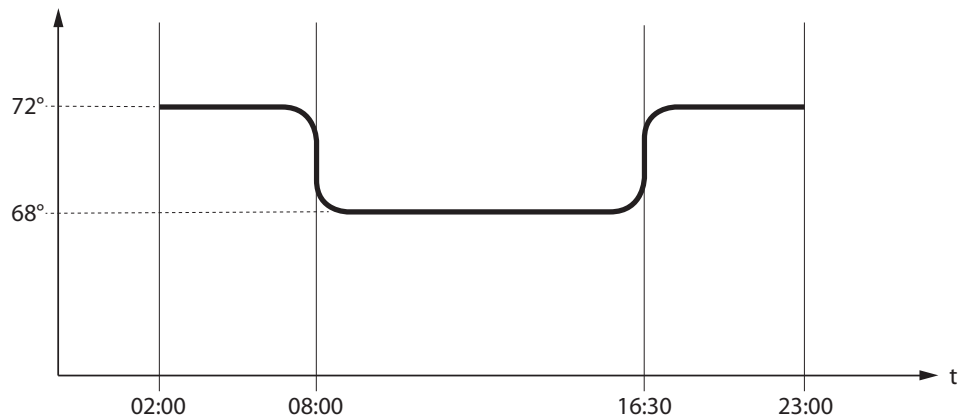

	Time slot 1	start 02:00 stop 23:00	power 3 - SET H2O 72°C
	Time slot 2	start 08:00 stop 16:30	power 1 - SET H2O 68°C
	stove operation		

SETTINGS

- **DATE-TIME**
- **LANGUAGE**
- **SET DEGREES**

SEE CHAPTER: FIRST IGNITION SETTINGS

DISPLAY

This menu allows you to adjust the brightness of the display. The values range from OFF, 1 to 20. If set to OFF, the display backlighting is set to maximum brightness and turns off after a 60 second delay.

The backlighting can be turned on again by pressing any key or if the stove is in alarm status.

CONTROLS PROCEDURE

- ◆ Press key 6.
- ◆ Press key 3 until **SETTINGS** appears and confirm by pressing key 6.
- ◆ Keep pressing key 3 until **DISPLAY** appears and confirm by pressing key 6.
- ◆ Use keys 4 -5 to set the desired intensity (**SET**)
- ◆ Press key 6 to confirm and key 1 to scroll back through the menus until the initial page.

STAND - BY

The **STAND-BY** function, if enabled, is used when stove switch-off is to be controlled by means of an additional thermostat

CONTROLS PROCEDURE

- ◆ Press key 6.
- ◆ Press key 3 until **SETTINGS** appears and confirm by pressing key 6.
- ◆ Keep pressing key 3 until **STAND-BY** appears and confirm by pressing key 6.
- ◆ Use keys 4-5 to enable (**ON**) / disable (**OFF**).
- ◆ Press 1 several times to confirm and exit the menu

FIRST LOAD

This function allows the auger to be filled, thus facilitating first stove ignition phases, or in the event the pellet hopper is empty.

With the stove cold and "OFF", make sure the pellets have been introduced inside the hopper and activate the **FIRST LOAD** function, confirming by pressing OK.

To interrupt continuous loading, simply press key 1 for 3 seconds.

CONTROLS PROCEDURE

- ◆ Press key 6.
- ◆ press key 3 until **SETTINGS** appears and confirm by pressing key 6.
- ◆ Keep pressing key 3 until **FIRST LOAD** appears and confirm by pressing key 6.
- ◆ Press key 1 several times to confirm and exit the menu.

OUTLET AIR

This function allows any air in the stove to be discharged. By activating the pump function, it will be powered alternatively with 30 second work phases and 30" stop for 15 minutes. With the stove cold and in "OFF", activate the **OUTLET AIR** function, pressing key 6 to confirm. To interrupt, press and hold key 1 for 3 seconds.

CONTROLS PROCEDURE

- ◆ Press key 6.
- ◆ Press key 3 until **SETTINGS** appears and confirm by pressing key 6.
- ◆ Keep pressing 3 until **OUTLET AIR** appears and confirm by pressing 6.
- ◆ Press key 1 several times to confirm and exit the menu.

CLEANING

This function allows to open the burn pot base, facilitating the combustion chamber cleaning operations.

CONTROLS PROCEDURE:

- ◆ Press key 6
- ◆ Press 3 until **SETTINGS** appears and confirm by pressing 6
- ◆ Keep pressing 3 until **CLEANING** appears and confirm by pressing 6
- ◆ Scrape the walls of the combustion chamber using the special tool supplied and let the residual ash drop into the ash drawer.
- ◆ Press key 1 to end and wait for the main screen to reappear.

OPEN THE DOOR ONLY WHEN THE OPERATION IS COMPLETE! THE DISPLAY WILL INDICATE THAT THE DOOR HAS BEEN OPENED!

Wi-Fi

The display allows internet connection using Wi-Fi technology.

This allows remote management and control of the stove using the dedicated APP for Smartphones, "TotalControl 2.0" (Apple Store / Play Store).

Follow the instructions given in the specific manual.

Visit the website: <https://www.lanordica-extraflame.com> > Accessories > WiFi remote module - Display Blackmask.

WI-FI ENABLING CONTROLS PROCEDURE

- ◆ Press key 6.
- ◆ Press key 3 until **SETTINGS** appears and confirm by pressing key 6.
- ◆ Keep pressing key 3 until **Wi-Fi** appears and confirm by pressing key 6.
- ◆ Press key 6 to access **ENABLING**.
- ◆ Use keys 4-5 to select enabling "ON"/ disabling "OFF" and press key 6 to confirm.
- ◆ Press key 1 several times to exit the menu.

CONTROLS PROCEDURE TO RESET WI-FI CONFIGURATION AND ENABLE ACCESS POINT

- ◆ Press key 6.
- ◆ Press key 3 until **SETTINGS** appears and confirm by pressing key 6.
- ◆ Press key 3 until **Wi-Fi** appears and confirm by pressing key 6.
- ◆ Press key 3 until **RESET** appears and the press key 6.
- ◆ Use keys 4-5 to select start reset "ON" / "OFF" and press key 6 to confirm.
- ◆ Press key 1 several times to exit the menu.

RESET

Allows the user to reset all editable values to the default values.

CONTROLS PROCEDURE

- ◆ Press key 6.
- ◆ Press key 3 until **SETTINGS** appears and confirm by pressing key 6.
- ◆ Press key 3 until **RESET** appears and confirm by pressing key 6.
- ◆ Use keys 4-5 for enabling "ON" or disabling "OFF"
- ◆ Press key 1 several times to confirm and exit the menu.

AUX

If the producer's conveyed wave accessories are used, the connection must be made by the qualified technician directly in the board. Contact the dealer for further details.

OPTIONAL ADDITIONAL DATA SHEET

The manufacturer has an optional additional data sheet which allows the boiler to have the following additional system management functions. The table below indicates the various possibilities that the optional can offer.

DHW Storage Management	✓
Buffer Tank management	✓
3 heating areas	✓
Instant DHW option	✓
Buffer tank pump or 4th heating area management	✓
Anti-legionella management for DHW storage	✓
DHW storage chrono management	✓
Auxiliary output management and control	✓

TO FIND OUT WHERE YOUR NEAREST SERVICE CENTRE IS, CONTACT YOUR DEALER OR VISIT THE WEBSITE:
WWW.LANORDICA-EXTRAFLAME.COM

CLEANING AND MAINTENANCE

ALWAYS FOLLOW THE INSTRUCTIONS IN COMPLETE SAFETY!

- ♦ Make sure that the power cord is unplugged because the generator may have been programmed to turn on.
- ♦ That the generator is cold all over.
- ♦ That the ashes are completely cold.
- ♦ Ensure efficient air exchange in the room during product cleaning operations.
- ♦ Poor cleaning will compromise correct operation and safety!

MAINTENANCE

For correct operation, the generator must undergo routine maintenance by a qualified technician, at least once a year. The periodic inspection and maintenance operations must always be performed by specialised, qualified technicians, who operate in accordance with the laws in force and the instructions given in this use and maintenance manual.



EVERY YEAR, HAVE THE FUME EXTRACTION SYSTEM, FLUE PIPES AND "T" FITTINGS, INCLUDING THE INSPECTION CAPS CLEANED. IF PRESENT, ALSO CLEAN THE ELBOWS AND HORIZONTAL SECTIONS! THE GENERATOR CLEANING FREQUENCY IS INDICATIVE! IT DEPENDS ON THE QUALITY OF THE PELLETS AND FREQUENCY OF USE. THESE OPERATIONS MAY SOMETIMES NEED TO BE PERFORMED MORE OFTEN

PERIODIC CLEANING UNDER USER'S RESPONSIBILITY

The periodic cleaning operations, as indicated in this use and maintenance manual, must be performed with the utmost care after reading the instructions, procedures and frequency described in this use and maintenance manual.

CLEANING THE SURFACES AND COVERING

Never use abrasive or chemically aggressive detergents for cleaning!

The surfaces must be cleaned when the generator and coating are completely cold. For the maintenance of the surfaces and metal parts, simply use a cloth dampened with water or water and neutral soap.

Failure to comply with these instructions may damage the surfaces of the generator and cause the invalidation of the warranty.

CLEANING THE CERAMIC GLASS

Never use abrasive or chemically aggressive detergents for cleaning!

The ceramic glass must be cleaned when the glass is completely cold.

To clean the ceramic glass, simply use a dry brush and some damp newspaper dipped in ash. If the glass is very dirty, use a specific cleaning agent for ceramic glass. Spray a small amount on a cloth and use it on the ceramic glass. Do not spray the cleaning agent or any other liquid directly on the glass or seals!

Failure to comply with these instructions may damage the surfaces of the ceramic glass and cause the invalidation of the warranty.

CLEANING THE PELLET HOPPER

When the hopper is completely empty, disconnect the power cord of the generator, remove the residue (dust, chippings, etc.) from the empty hopper and then fill it up.

THE FOLLOWING IMAGES ARE FOR ILLUSTRATIVE PURPOSES.

SCRAPERS:

The heat exchangers must only be cleaned when cold! Its cleaning guarantees constant heat output over time. This maintenance must be performed at least once a day. To do this, use the scrapers positioned in the upper part of the generator, making upward and downward moments several times.

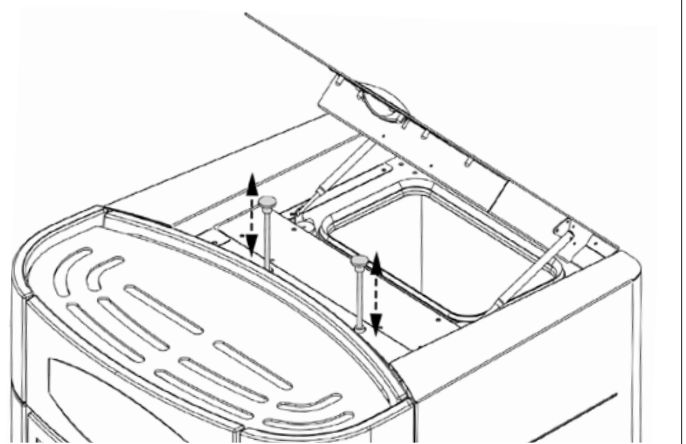

THE IMAGES ARE FOR ILLUSTRATIVE PURPOSES.

BURN POT AND COMBUSTION CHAMBER:

By means of a mechanical system, the burn pot is cleaned automatically at preset intervals. It is **however advisable to remove any residues by means of a vacuum cleaner.**

- ◆ Suck the ash deposited between the partition (A) and the fire door.
- ◆ Remove the conveyor (B).
- ◆ Clean the combustion ash chamber and the bottom of the burn pot completely, using a suitable vacuum cleaner.
- ◆ Refit the conveyor (B) on the burn pot.

To clean the burn pot, it is necessary to remove the conveyor (B); see picture.

To remove it, simply lift it off the burn pot.

After cleaning the burn pot, always make sure that the conveyor (B) rests on the burn pot correctly and not on another area of the combustion chamber.

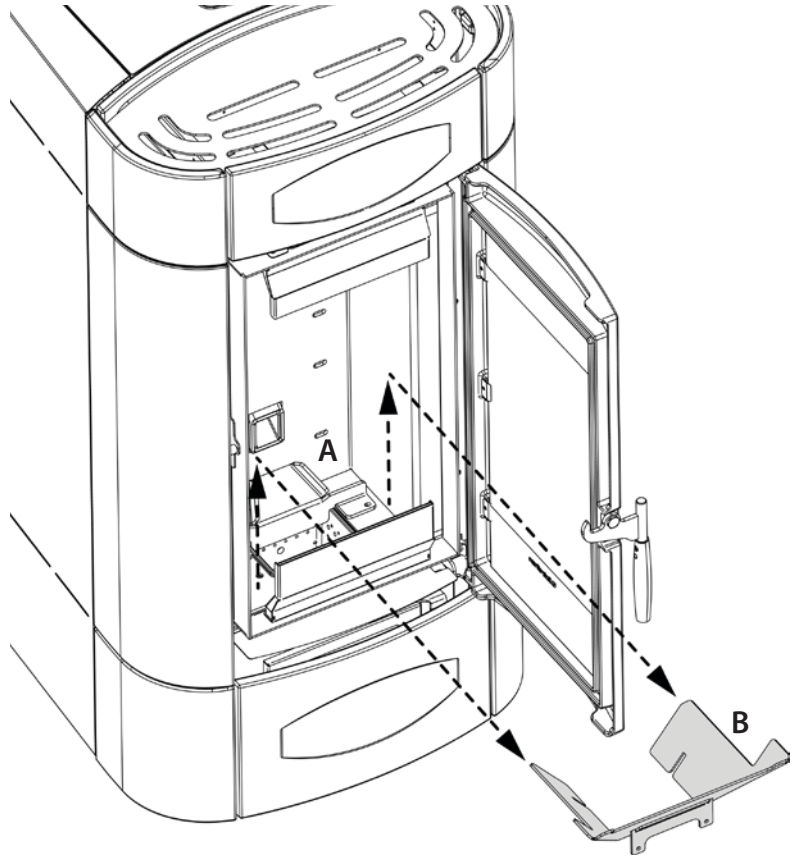

DETAILS ON BURN POT CLEANING

During the brazier cleaning operations, make sure to remove the ashed behind the pellet chute. Insert the supplied poker behind the pellet chute (A) removing the deposits. Then aspirate the ashes with an adequate vacuum cleaner.

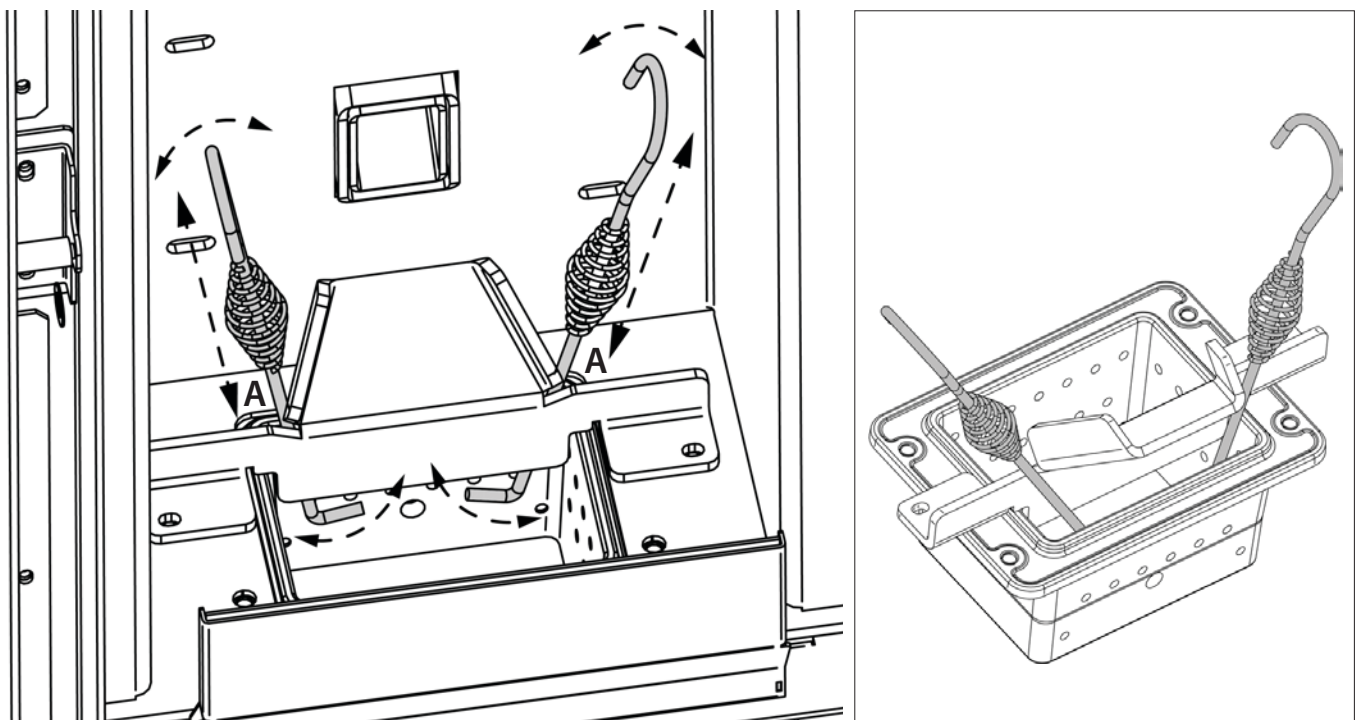



**A CLEAN BURN POT GUARANTEES CORRECT OPERATION!
BY KEEPING THE BURN POT AND ITS HOLES CONSTANTLY CLEAN AND FREE OF
COMBUSTION RESIDUE, EXCELLENT COMBUSTION IS GUARANTEED OVER TIME,
THUS PREVENTING ANY GENERATOR MALFUNCTIONS THAT MAY REQUIRE
TECHNICAL ASSISTANCE.
THE "EASY SETUP" FUNCTION IN THE USER MENU CAN BE USED TO ADAPT
COMBUSTION ON THE BASIS OF THE NEEDS DESCRIBED.**

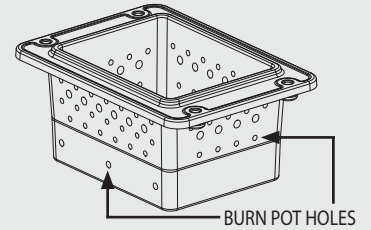

ASH DRAWER:

Remove the ash drawer and empty it into a suitable container.

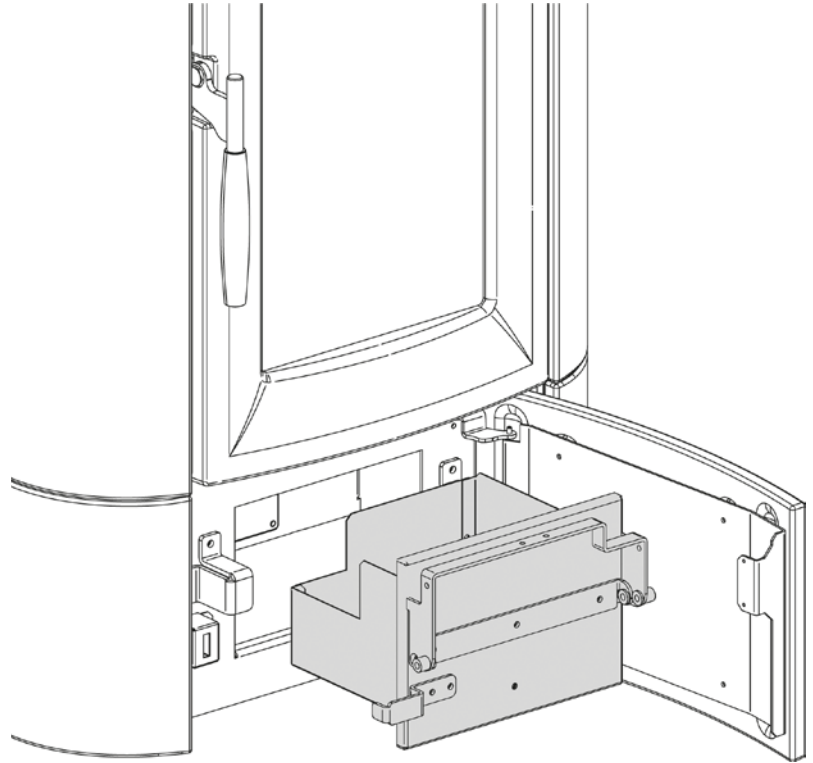

Remove any ash residues from the intake air pipe.

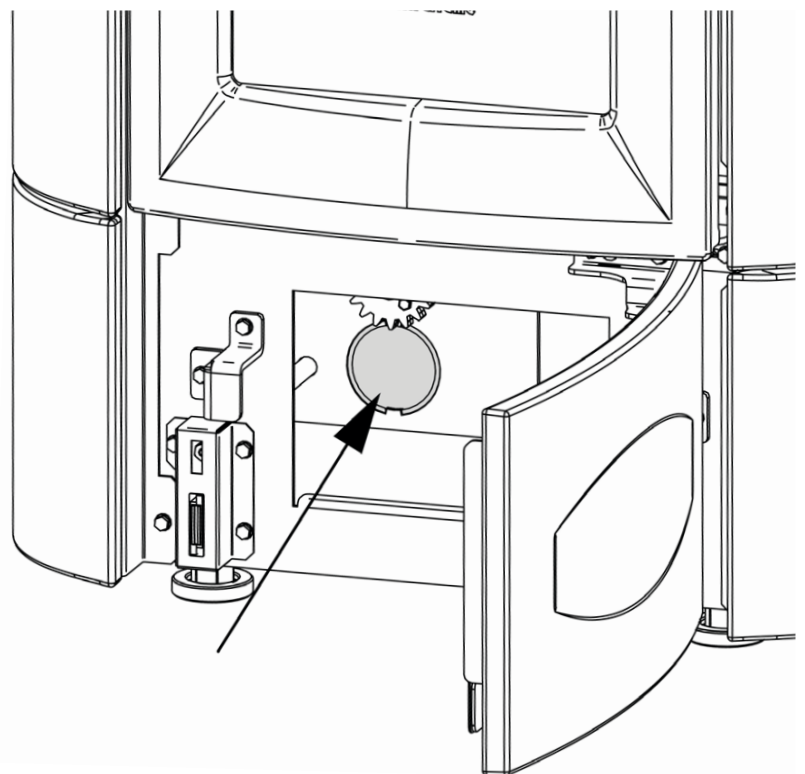

THE IMAGES ARE FOR ILLUSTRATIVE PURPOSES.

PARTIES	FREQUENCY IN DAYS*
SCRAPERS	7
BURN POT	7
COMBUSTION CHAMBER	7
ASH DRAWER**	7
T-SHAPED FITTING/ FLUE PIPE	365

* 8h average use at maximum power.

**How often the ash drawer is emptied depends on a number of factors: the type of pellets, the stove output, the use of the stove and the type of installation.



IF THE POWER CORD IS DAMAGED, IT MUST BE REPLACED BY THE SERVICE CENTRE OR BY A SIMILARLY QUALIFIED PERSON, SO AS TO AVOID ALL RISKS.

**TO FIND OUT WHERE YOUR NEAREST SERVICE CENTRE IS, CONTACT YOUR DEALER OR VISIT THE WEBSITE:
WWW.LANORDICA-EXTRAFLAME.COM**

ROUTINE MAINTENANCE PERFORMED BY QUALIFIED TECHNICIANS

Routine maintenance must be performed at least once a year.

Given the generator uses pellets as solid fuel, it requires annual routine maintenance, which must be performed by a **Qualified technician, using only original spare parts.**

Failure to comply may jeopardise safety of the appliance and invalidate the warranty conditions.

By observing the cleaning schedule reserved to the user described in the use and maintenance manual, the generator will be guaranteed correct combustion over time, thus preventing any faults and/or malfunctions which may require subsequent technical assistance. Requests for routine maintenance are not covered by the warranty.

GASKETS: PELLET HOPPER LID, DOOR, ASH DRAWER AND BURN POT

The gaskets ensure the proper sealing of the stove and therefore its proper operation.

They must be periodically checked and immediately replaced if worn or damaged.

These operations must be carried out by a qualified technician.

CONNECTION TO THE FLUE

Annually, or in any case each time the flue pipe needs to be vacuumed and cleaned. If there are horizontal sections, the residue must be removed to prevent it from obstructing the flow of fumes.

SHUT-DOWN (END OF SEASON)

At the end of each season, before turning the stove off, it is advisable to completely empty the pellet hopper, removing any pellet residue and dust with a vacuum cleaner.

IT IS ADVISABLE NOT TO DISCONNECT THE GENERATOR FROM THE POWER SUPPLY TO ALLOW THE PUMP TO CARRY OUT THE NORMAL ANTI-BLOCK CYCLES.

Routine maintenance must be performed at least once a year.

THE IMAGES ARE FOR ILLUSTRATIVE PURPOSES.

TO FIND OUT WHERE YOUR NEAREST SERVICE CENTRE IS, CONTACT YOUR DEALER OR VISIT THE WEBSITE:
WWW.LANORDICA-EXTRAFLAME.COM

THE IMAGES ARE FOR ILLUSTRATIVE PURPOSES.

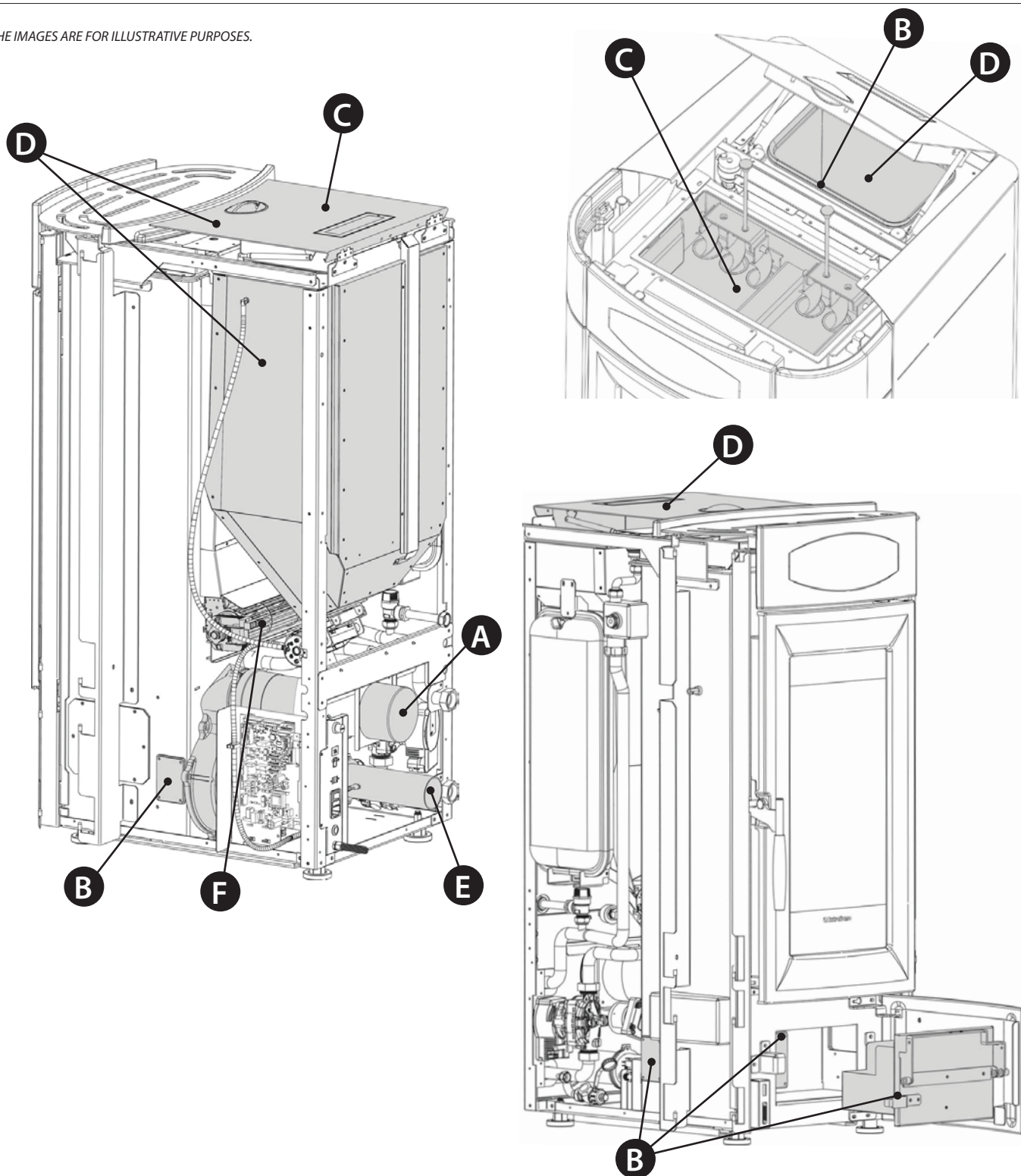



A	Fumes motor (disassembly and cleaning and fumes pipe and "T"), new silicone in the provided points
B	Gaskets, pellet hopper, inspections, ash drawer and door (replace and apply silicone where indicated)
C	Combustion chamber and heat exchanger (full cleaning) including ignition plug pipe
D	Hopper (complete emptying and cleaning).
E	Check air intake pipe and cleaning of the flow sensor
F	Remove the ambient air fan and remove any dust and pellet residue.

DISPLAYS

DISPLAY	REASON
OFF	Generator off
START	The start-up phase is in progress
PELLET LOADING	Continuous pellet loading is in progress during the ignition phase
IGNITION	The ignition phase is in progress
PREPARATION	The preparation phase is in progress
WORK	The normal work phase is in progress
MODULATION	The generator is working at minimum
BLOW	The automatic blow is active
CLEANING	The routine cleaning of the burn pot is in progress.
FINAL CLEANING	The final cleaning is in progress
STAND-BY	Generator off waiting for re-ignition due to an external thermostat
COOLING - WAITING TIME	A new ignition is attempted when the generator has just been switched off. When the generator switches off, one must wait for the complete shutdown of the fumes motor, then clean the burn pot. The generator can only be re-ignited when these operations have been performed.
H-OFF	Generator off due to water temperature over set.
TOFF	Generator off waiting for re-ignition due to all requests met
BLACK OUT STAND BY	The generator is cooling after a power cut. Once cooling is completed, it will re-start automatically
ANTI-FREEZING	The anti-freezing function is in progress as the H ₂ O temperature is below the factory set threshold the pump is active until the water reaches the pre-set factory parameter +2°C
ANTI-BLOCK	The pump anti-block function is in progress (only if the generator has been in an OFF state for at least 96 hours); the pump is activated for the time pre-set by the manufacturer, in order to prevent it from blocking
CLOSE HOPPER - STOVE DOOR	Check that the pellet hopper and the combustion chamber door are closed correctly. Check air inlet.

ALARMS

DISPLAY	EXPLANATION	SOLUTION
	Indicates the presence of an alarm.	On: indicates the presence of an alarm Flashing: indicates the deactivation of the depression sensor. The alarm can be reset only if the fumes motor has stopped and 15 minutes have passed since the alarm was displayed, by pressing the key 1/  for 3 seconds.
FUMES MOTOR FAULT	Fumes motor fault	Contact after-sales centre
FUMES PROBE	Fumes probe fault.	Contact after-sales centre
HOT FUMES	High fumes temperature	Check pellet feed (see " EASY SETUP "), if the problem cannot be solved, contact an authorised technician.
CHAMB PROBE	Chamber probe fault.	Contact the after-sales centre.

NO FLAME	The pellet hopper is empty. No pellet feed. The gearmotor does not feed pellets.	Check for the presence of pellets in the hopper. Adjust the pellet flow (see " EASY SETUP ").
DEPR ALARM	The door is not closed correctly. The ash drawer is not closed correctly. The combustion chamber is dirty. The fumes exhaust pipe is blocked/dirty	Check hermetic door closure. Check hermetic closure of the ash drawer. Check cleanliness of the fumes pipe and the combustion chamber.
NO IGNITION	The pellet hopper is empty. Pellet feed calibration inadequate. Thermostat bulbs tripped.	Check for the presence of pellets in the hopper. Adjust the pellet flow (see " EASY SETUP "). Check the procedures described in the "Ignition" chapter. Check bulb thermostats (see chapter on Resetting)
NO IGNITION BLACK OUT	No current during the ignition phase.	Take the stove to OFF conditions using key 1 and repeat the procedure described in the "Ignition" chapter.
COMMAND AUGER ALARM	Abnormal pellet loading.	Contact after-sales centre
AUGER BLOCKED	Abnormal operation of pellet motor	Contact after-sales centre
MAX ELECTRICAL CURRENT	The automatic cleaning of the burn pot is blocked. Burn pot dirty or clogged or door not closed properly	Check that the door is closed properly Check that the burn pot is free and clean If the problem persists, contact the after-sales centre.
MIN H2O PRESSURE ALARM	The system pressure read by the pressure switch is too low.	Possible air in the system; bleed the system. Possible lack of water or leaks due to anomalies in some system component. If the problem persists, contact the service centre.
MAX H2O PRESSURE ALARM	Air in the system Inadequate circulation	Possible air in the system; bleed the system. Lack of adequate circulation. Lack of or inadequate safety zone. The water in the stove has exceeded 95°C. Possible pump anomaly. If the problem persists, restore operations must be performed by an authorised technician.
H2O PROBE	H2O probe fault	Contact after-sales centre
* DHW PROBE	Fault in DHW probe .	Contact after-sales centre
* BUFFER TANK PROBE	Fault in Buffer tank probe .	Contact after-sales centre
TRAPDOOR BLOCKED	The automatic cleaning of the burn pot is blocked. Burn pot dirty or clogged The door is not closed correctly.	Check that the door closes correctly. Check that the burn pot is clear and clean. The automatic cleaning of the burn pot is blocked. If the problem persists, contact the service centre.
BLOCKED PWM ALARM	The pump has stopped permanently Pump blocked. Electronic module damaged	Contact after-sales centre
HOT PWM ALARM	The pump is operating but not with good performance. Undervoltage 160-194V. Pump in circuit breaker protection mode.	Contact after-sales centre
STOPPED PWM ALARM	The pump has stopped but is still operational. Undervoltage < 160V Overvoltage. Unexpected external flow.	Contact after-sales centre
STOPPED 2 PWM ALARM	The pump has stopped but is still operational. Problem in a component different to the pump. Debris in installation. Positioning in high temperature.	Contact after-sales centre
FLOW PWM ALARM	Pump blocked. Liquid with high density. Pipe obstructed. Presence of air in the system.	Contact after-sales centre
PWM INTERFACE ALARM	iPWM output interface damaged, in short circuit or not connected	Contact after-sales centre

* if there is an additional system data-sheet.

TO FIND OUT WHERE YOUR NEAREST SERVICE CENTRE IS, CONTACT YOUR DEALER OR GO TO THE WEBSITE WWW.LANORDICA-EXTRAFLAME.COM

GUARANTEE TERMS

1. EXTRAFLAME S.p.A. products are guaranteed, within the European community, for 24 months from the date of purchase. Purchase has to be proved by means of a valid fiscal document issued by the seller (receipt, invoice or shipment document) identifying the purchased product and its purchase and/or delivery date.

WARNING: *This conventional guarantee does not replace the guarantee regulated by the European legislation on consumer rights.*

The conventional guarantee is only applicable to the Italian region and to those areas, within the European Community, where the Authorised Technical Assistance Centres are active (see the www.lanordica-extraflame.com website)

It is also limited to the state of residence of the consumer, which must coincide with the premises and/or registered office of the seller of the EXTRAFLAME S.p.A. product

These regulations do not apply if the product is purchased within commercial, entrepreneurial, or professional circumstances. In these cases the product guarantee will be limited to a period of 12 months from the date of purchase.

ITALIAN GUARANTEE

What must be done if there is a product malfunction:

Consult the instructions manual to make sure the malfunction cannot be solved by using the product correctly. Make sure the malfunction is included in those covered by the guarantee; otherwise the cost of the intervention will be borne entirely by the consumer. When requesting the intervention of the Assistance service at the Authorised Assistance Centre, always specify: - type of malfunction - model of the appliance - complete address - phone number

EUROPEAN GUARANTEE

What must be done if there is a product malfunction:

Consult the instructions manual to make sure the malfunction cannot be solved by using the product correctly. Make sure the malfunction is included in those covered by the guarantee; otherwise the cost of the intervention will be borne entirely by the consumer. Request the intervention of the Assistance service or the address of the Authorised Technical Assistance Centre to the seller; always specify: type of malfunction, model of the appliance, complete address and phone number

If the malfunction arises in the first 6 months of the product's life, the consumer has the right to have the product repaired with no expense. From the seventh to the twenty-fourth month, if a malfunction arises, the consumer will bear the cost of the call, while the seller will pay for the manpower and for any spare parts used.

2. If the malfunction is linked to external events and/or conditions such as, including but not limited to, insufficient capacity of the systems; wrong installation and/or maintenance by the personnel which hasn't got the skills prescribed by the laws of the country of residence of the consumer; negligence; inability to use the product and wrong maintenance by the consumer, with respect to what is reported and recommended by the instructions manual of the product, which is part of the sales contract, this guarantee will be void.

Damage to the product that cannot be related to manufacturing defects are also not included in this guarantee. Similarly are excluded defects related to incorrect operation of the flue, according to the legislation in force in the country at the moment of purchase. Other exclusions include all product defects due to carelessness, accidental breakdown, tampering and/or damage during transport (scratches, dents, etc.), interventions carried out by unauthorised personnel and further damage caused by incorrect interventions by the consumer trying to arrange the initial malfunction.

The following consumables are excluded by the guarantee: gaskets, ceramic or tempered glasses, cast iron grilles or coatings, refractory materials (e.g. Nordiker or others), painted, chrome-plated or golden parts, majolica ware, handles, the brazier and its related components. For Idro products the heat exchanger is not covered by the guarantee if a suitable condensation-proof circuit is not set up to ensure a return temperature of the device of at least 55°C. The guarantee excludes all the external components on which the consumer can directly operate during use and/or maintenance or that can be subject to wear and/or rust and stains on steel due to aggressive detergents.

If malfunctions are signalled which are not later confirmed during check by an authorised technician, the cost of the intervention will be borne entirely by the consumer.

3. If it is not possible to restore product conformity by repairing it, the product/component will be replaced, the guarantee expiration date and conditions will remain the same established when the product/component to be replaced has been purchased.

4. EXTRAFLAME S.p.A. cannot be held liable for injury or damage which may - either directly or indirectly - be caused to persons, animals and property ensuing from failure to observe all the instructions provided in the relevant instruction manual and the warnings regarding installation, use and maintenance of the product, that can also be downloaded on the website.

5. Interventions for adjusting and/or regulating the product for the type of fuel or other reasons are excluded by the guarantee.

6. If the product is repaired in one of the Authorised Technical Assistance Centres indicated by EXTRAFLAME S.p.A. and if the product is replaced, transport will be free of charge. If the technician can repair the product at the user's place of residence and they refuse, transport to the workshop and redelivery will be paid by the consumer.

7. After the 24 months of the guarantee have elapsed any repair intervention cost will be completely borne by the consumer.

8. In the case of disputes the only competent court is that of the EXTRAFLAME S.p.A. registered office - (Vicenza-Italy)

ADDITIONAL WARNINGS

- ◆ Only use the fuel recommended by the manufacturer. The product must not be used as an incinerator.
- ◆ Do not use the product as a ladder or supporting structure.
- ◆ Do not place laundry on the product to dry it. Any clothes-horse or similar objects must be kept at due distance from the product. Danger of fire or damage to the coating.
- ◆ The user is fully liable for any incorrect use of the product. The manufacturer bears no civil or criminal liability for incorrect use.
- ◆ Unauthorised tampering of any nature or replacement of spare parts of the product with non-original parts may endanger the operator and the manufacturer bears no civil or criminal liability for this.
- ◆ Large parts of the surface of the product can get very hot (door, handle, glass, smoke outlet pipes, etc.). Please therefore avoid coming into contact with these parts without wearing suitable protective clothing or using appropriate measures, such as heat protective gloves.
- ◆ DO NOT use the product with the door open or if the glass is broken.
- ◆ The product must be electrically connected to a system equipped with an operational earthing system.
- ◆ Turn off the product in the event of a failure or malfunctioning.
- ◆ Unburned pellets that build up in the burner following each failed start-up must be removed before attempting to start up the product again. Make sure that the burner is clean and correctly positioned before starting it up again.
- ◆ Do not wash the product with water. Water may penetrate into the unit and cause faults in the electrical insulation. This can cause electric shocks.
- ◆ Installations not complying with the regulations in force, as well as incorrect use and failure to comply with the maintenance scheduled by the manufacturer, will invalidate the guarantee.

DISPOSAL

INFORMATION FOR MANAGEMENT OF ELECTRIC AND ELECTRONIC APPLIANCE WASTE CONTAINING BATTERIES OR ACCUMULATORS



This symbol, which is used on the product, batteries, accumulators or on the packaging or documents, means that at the end of its useful life, this product, the batteries and the accumulators included must not be collected, recycled or disposed of together with domestic waste. Improper management of electric or electronic waste or batteries or accumulators can lead to the leakage of hazardous substances contained in the product. For the purpose of preventing damage to health or the environment, users are kindly asked to separate this equipment and/or batteries or accumulators included from other types of waste and to arrange for disposal by the municipal waste service. It is possible to ask your local dealer to collect the waste electric or electronic appliance under the conditions and following the methods provided by national laws transposing the Directive 2012/19/EU.

Separate waste collection and recycling of unused electric and electronic equipment, batteries and accumulators helps to save natural resources and to guarantee that this waste is processed in a manner that is safe for health and the environment.

For more information about how to collect electric and electronic equipment and appliances, batteries and accumulators, please contact your local Council or Public Authority competent to issue the relevant permits.

Extraflame®

Riscaldamento a Pellet

EXTRAFLAME S.p.A. Via Dell'Artigianato, 12 36030 - MONTECCHIO PRECALCINO (VI) - ITALY
☎ +39.0445.865911 - 📠 +39.0445.865912 - ✉ info@extraflame.it - 🌐 www.lanordica-extraflame.com

MADE IN ITALY
design & production

*TO FIND THE SERVICE CENTRE NEAREST TO YOU
CONTACT YOUR DEALER OR CONSULT
THE SITE WWW.LANORDICA-EXTRAFLAME.COM*

The manufacturer reserves the right to vary the characteristics and the data reported in this pamphlet at any moment and without notice, in order to improve its products.
This manual, therefore, cannot be regarded as a contract towards other parties.